

Bauanleitung
Assembly manual
Mode d'emploi
Handleiding
Instrucción de montaje
Istruzione al montaggio

MASTER

DISCOVERY



Download von www.ft-fanarchiv.de
gescannt von Andreas Wyrobek
Überarbeitung und PDF von Peter

fischertechnik®



7

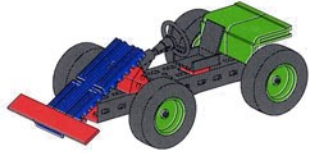

Discovery Racer

9

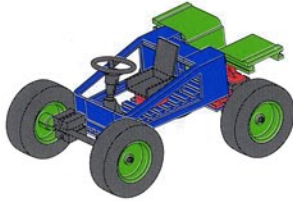

Mountain Jeep

11



Beach Buggy

13

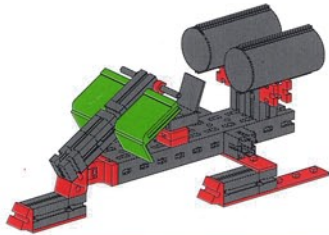

Snow Cat

15

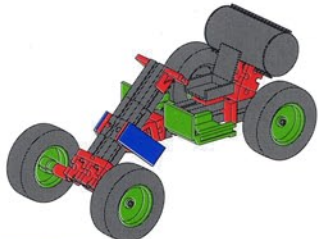

Ice Patroller

17

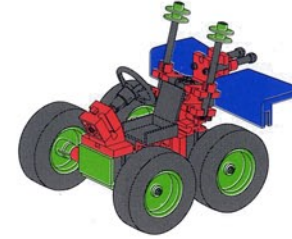

Canyon Explorer

19

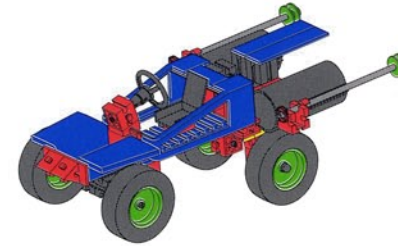

Moon Racer

21

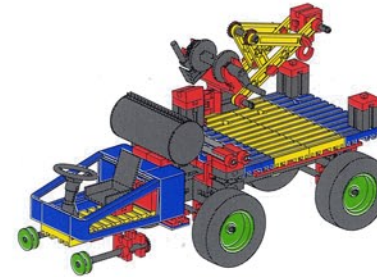

Freight Truck

25

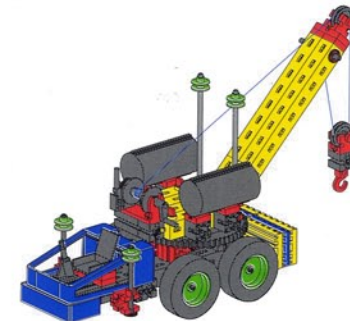

Crane Truck

32

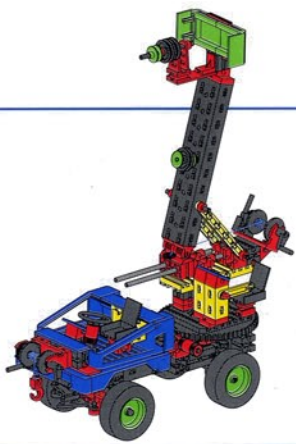

Radio Service

39



Planet Scout

43

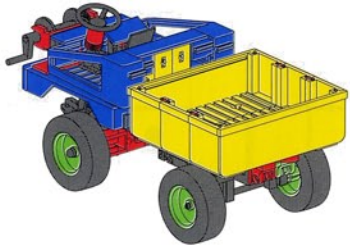

Pickup Truck

48

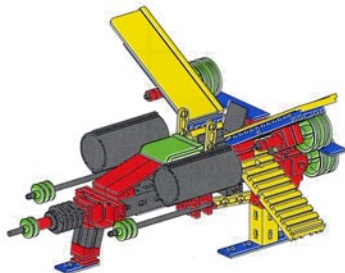

X-Wing Glider

51

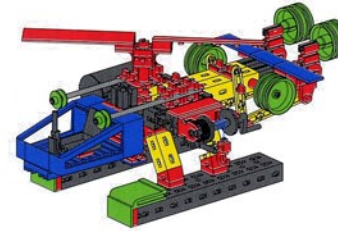

Air Commander

55

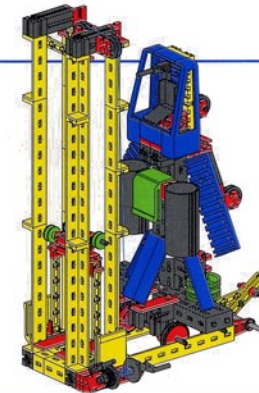

Shuttle Base

59

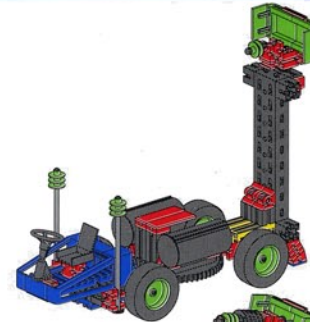

Radar Control



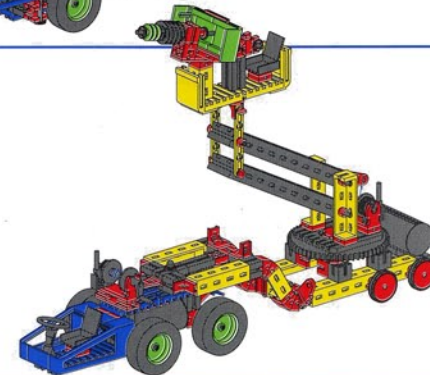





















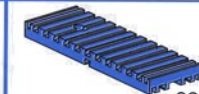

















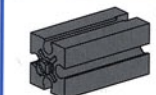

62



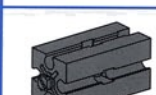























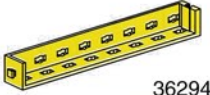



































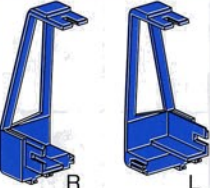





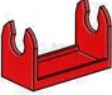











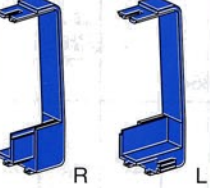

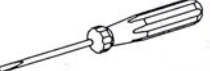

Polaris Trailer

Einzelteilübersicht
Spare parts list
Liste des pièces détachée

Onderdelenoverzicht
Lista de piezas
Lista dei pezzi

	MASTER Discovery	MASTER Discovery + SMotor	MASTER Plus Discovery Set		MASTER Discovery	MASTER Discovery + SMotor	MASTER Plus Discovery Set		MASTER Discovery	MASTER Discovery + SMotor	MASTER Plus Discovery Set		MASTER Discovery	MASTER Discovery + SMotor	MASTER Plus Discovery Set		MASTER Discovery	MASTER Discovery + SMotor	MASTER Plus Discovery Set
 60° 31010	2x	2x		 31426	2x	2x		 31843	2x	2x		 31983	4x	4x		 32856	2x	2x	
 30° 31011	8x	8x		 31436	2x	2x		 31850	1x	1x		 31997	2x	2x		 32858	6x	6x	
 31017	4x	4x		 31614	1x	1x		 31854	1x	1x		 31998	2x	2x		 32860	2x	2x	
 31026	1x	1x		 31667	2x	2x		 31905	1x	1x	1x	 31999	2x	2x		 32861	3x	3x	
 110 31031	2x	2x		 31674	4x	4x		 31909	1x	1x	1x	 32064	3x	3x		 32869	2x	2x	
 31058	4x	4x		 31675	1x	1x		 31915	2x	2x		 32850	6x	6x		 32870	2x	2x	
 30 31061	6x	6x		 31690	5x	5x		 31916	1x	1x		 32851	1x	1x		 32879	4x	4x	
 31390	1x	1x		 30 31764	6x	6x		 15° 31981	4x	4x		 32852	1x	1x		 32880	2x	2x	
 31391	1x	1x		 31766	2x	2x		 31982	6x	14x	8x	 32854	2x	2x		 32881	8x	8x	

	MASTER Discovery	MASTER Discovery + SMotor	MASTER Plus Discovery Set		MASTER Discovery	MASTER Discovery + SMotor	MASTER Plus Discovery Set		MASTER Discovery	MASTER Discovery + SMotor	MASTER Plus Discovery Set		MASTER Discovery	MASTER Discovery + SMotor	MASTER Plus Discovery Set		MASTER Discovery	MASTER Discovery + SMotor	MASTER Plus Discovery Set
 32882	4x	4x		 98 35414	2x	2x		 36699	2x	2x	2x	 37679	10x	10x		 30 38413	1x	1x	
 32884	1x	1x		 35797	5x	5x		 36700	4x	4x	4x	 38225	1x	1x		 50 38415	1x	1x	
 32885	1x	1x		 35998	2x	2x		 36701	8x	8x	8x	 38240	4x	4x		 60 38416	2x	2x	
 32886	1x	1x		 36294	8x	8x		 36702	2x	2x	2x	 38242	2x	2x		 38423	2x	2x	
 32887	2x	2x		 36297	8x	8x		 36703	4x	4x	4x	 38245	2x	2x		 38428	2x	2x	
 32888	1x	1x		 36298	2x	2x		 37237	14x	14x		 38260	2x	2x		 60 38540	2x	2x	
 32913	4x	4x		 36299	4x	4x		 37238	8x	8x		 38267	5x	5x		 45 38541	4x	4x	
 35031	4x	4x		 36323	48x	48x		 37468	4x	6x	2x	 38277	4x	4x		 42 A 38542	16x	16x	
 35113	1x	1x		 36334	8x	8x		 37636	7x	7x		 38324	4x	4x		 15 38544	1x	1x	

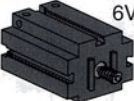
	MASTER Discovery	MASTER Discovery + SMotor	MASTER Plus Discovery Set		MASTER Discovery	MASTER Discovery + SMotor	MASTER Plus Discovery Set		MASTER Discovery	MASTER Discovery + SMotor	MASTER Plus Discovery Set		MASTER Discovery	MASTER Discovery + SMotor	MASTER Plus Discovery Set		
 38545	2x	2x		 31864	1x	1x		 32263	1x	1x		 35066	1x	1x	 31078	1x	1x
 38772 R 38773 L	1x R	1x R		 31923	2x	2x		 32958	1x	1x		 36382	1x	1x	 35061	1x	1x
	1x L	1x L		 31925	2x	2x		 35069	1x	1x		 36708	1x	1x	 35062	1x	1x
 38776	1x	1x		 31856	2x	2x		 35070	1x	1x		 32233	1x	1x	 35945	1x	1x
 38777	1x	1x		 32957	1x	1x		 35073	2x	2x		 35116	3x	3x	 36227	1x	1x
 38780 R 38781 L	1x R	1x R		 31869	1x	1x		 31082	1x	1x		 35117	3x	3x	 36443	1x	1x
	1x L	1x L		 31872	2x	2x		 35063	1x	1x		 38213	6x	6x			
 31851	1x	1x		 31877	2x	2x		 35064	1x	1x		 38214	6x	6x			
 31863	1x	1x						 35065	1x	1x		 32293	1x	1x			

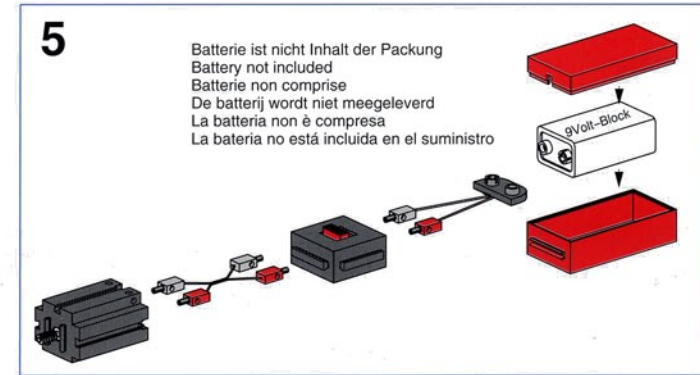
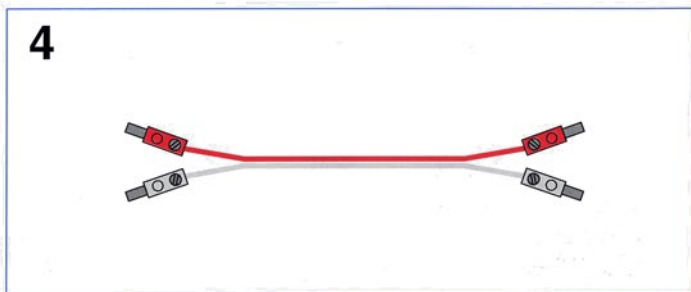
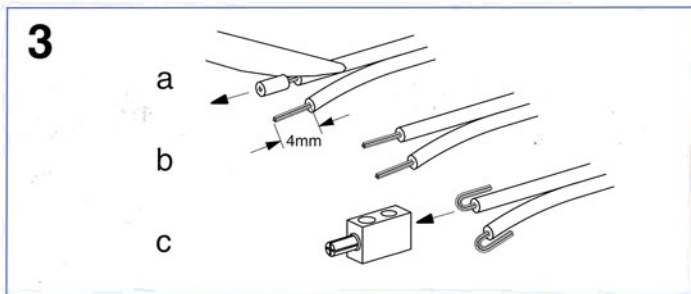
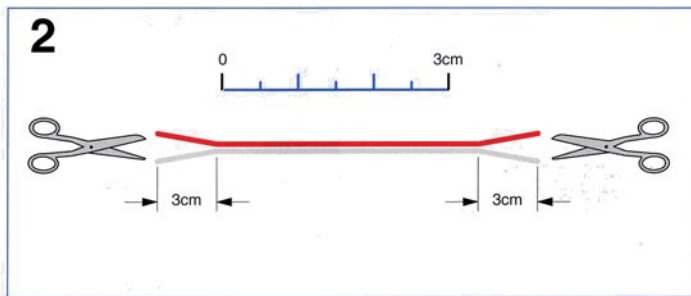
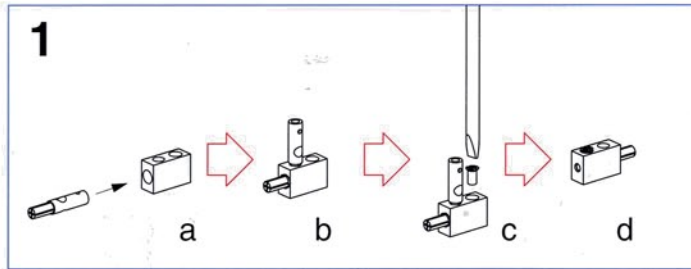

1 Akku oder 1 Batterie (9Volt-Block)

- Leere Akkus zum Laden entnehmen.
- Verbrauchte Batterien dem Sondermüll zuführen.

1 rechargeable battery or 1 dry cell

- Remove discharged battery and place in charger for recharging.
- Discard spent dry cells at special waste disposal centre.

1 accu où 1 pile

- Pour recharger les accus vides, il faut les sortir et les placer dans le chargeur.
- Jeter les piles usagées dans un conteneur spécial réservé à cet effet.

1 oplaadbare batterij of 1 batterij

- Voor het opladen van batterijen de lege batterijen uit nemen en met behulp van het oplaadapparaat opladen.
- Afleveren gebruikte batterijen bij het klein chemisch afval (KCA).

1 batteria ad accumulatore o 1 batteria normale (9Volt)

- Togliere le batterie ad accumulatore scariche per ricaricarle.
- Gettare le batterie scariche negli appositi cassonetti di raccolta differenziata.

1 acumulador oppure 1 batería

- Retirar el acumulador descargado y colocarlo en el cargador
- Retirar las baterías viejas, desechándolas en un depósito de basuras especiales.

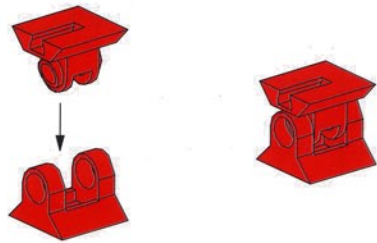
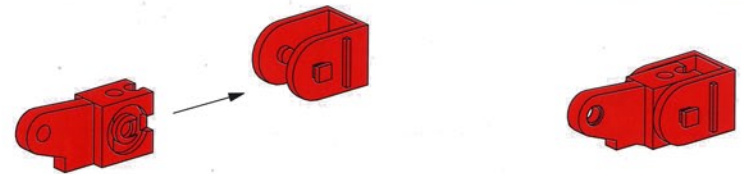
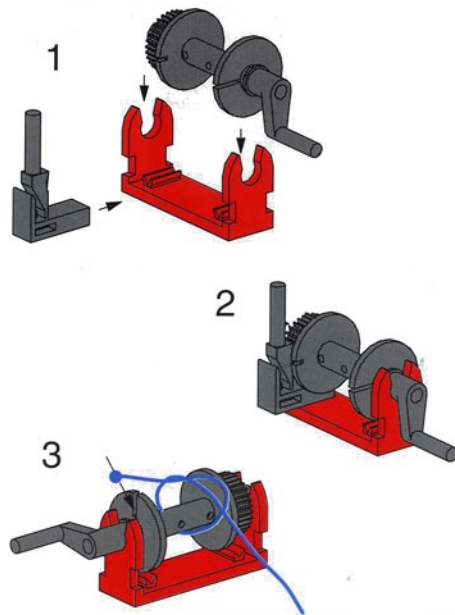
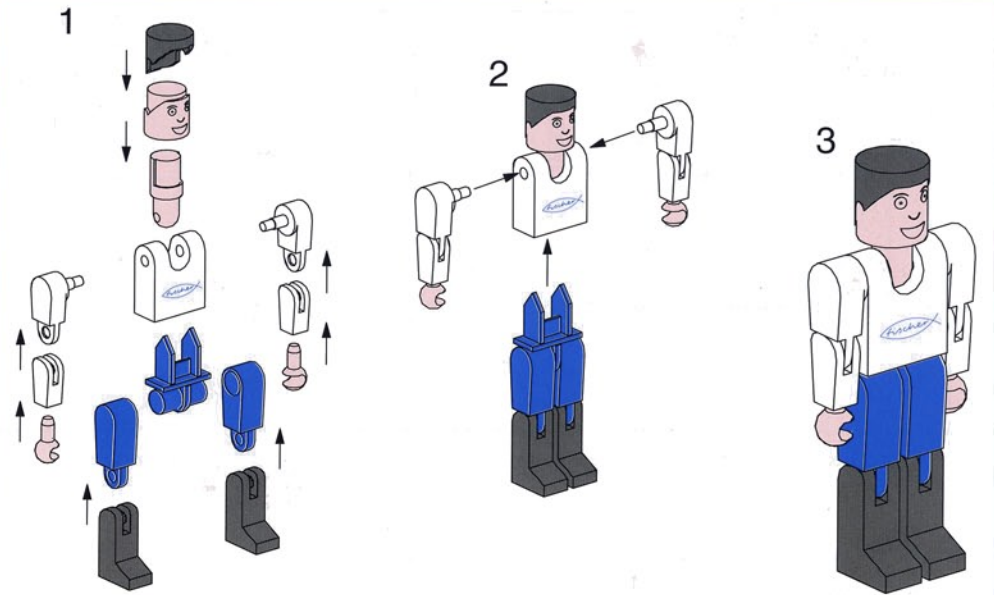
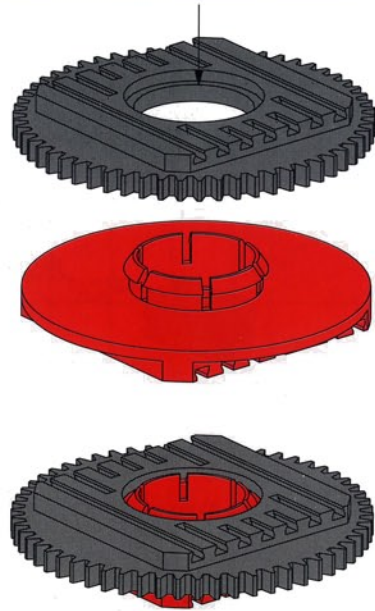
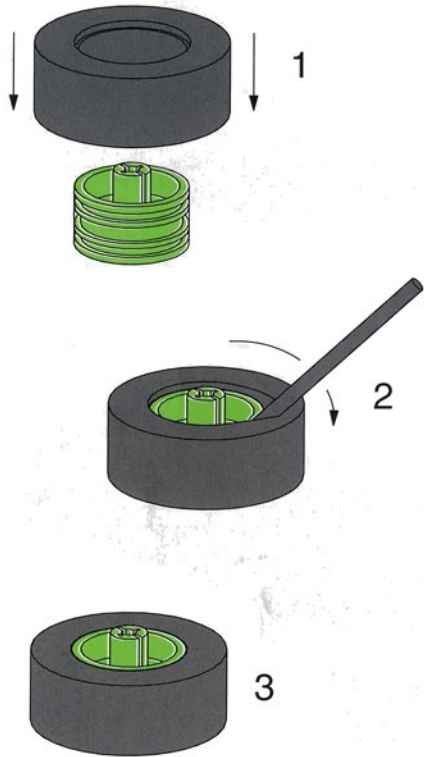

Master Discovery + S-Motor

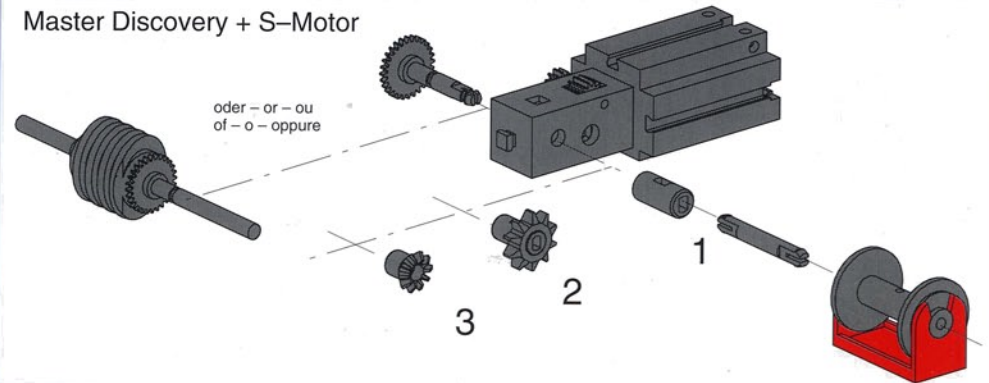

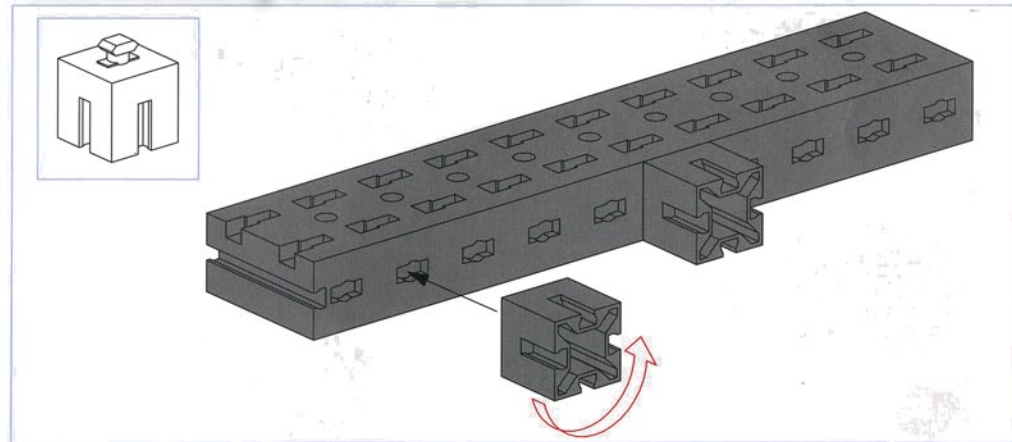
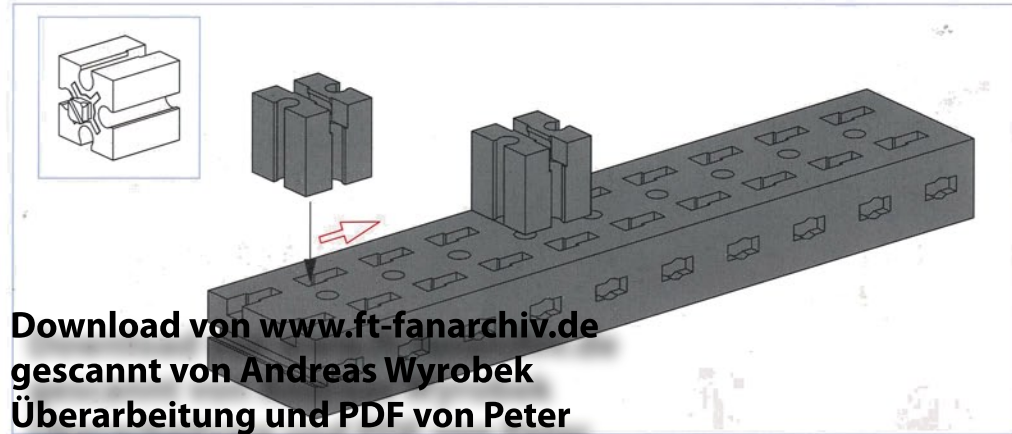
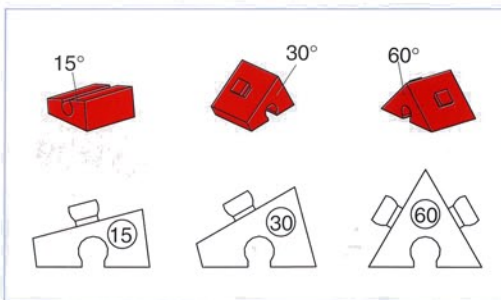
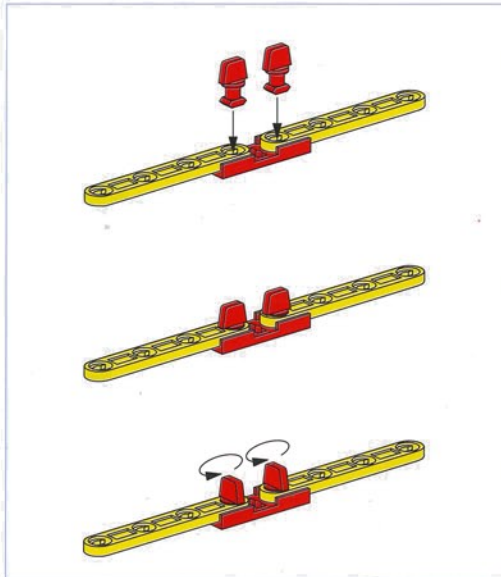
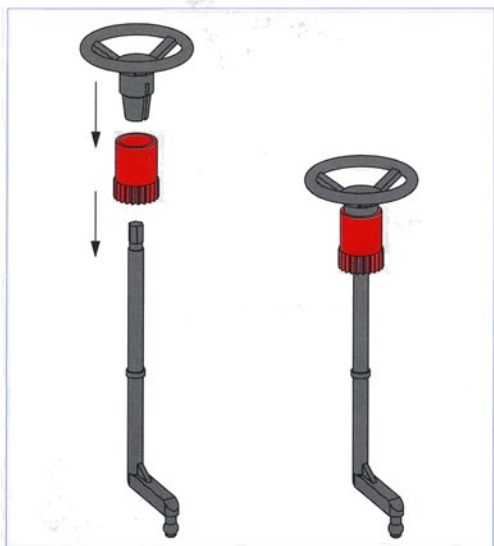
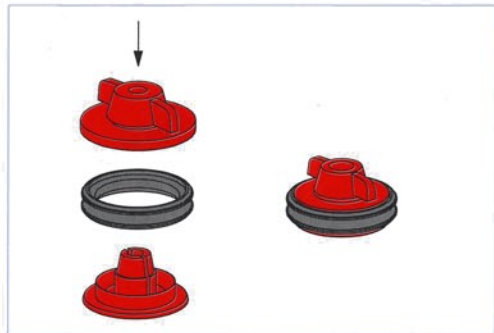
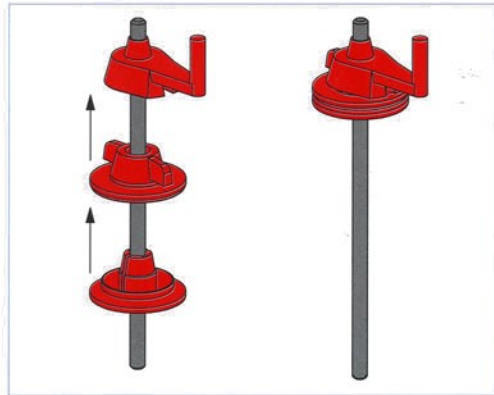

Achtung
 Verletzungsgefahr an Bauteilen mit funktionsbedingten scharfen Kanten und Spitzen!

Caution
 Be careful not to hurt yourself on components with sharp or pointed edges!

Attention
 Risque de blessure sur les éléments comportant des arêtes et pointes vives indispensables au bon fonctionnement!

Let op
 U kunt zich bezeren aan bouwstenen met scherpe randen of punten!

Attenzione
 Esiste il pericolo di lesione con i pezzi di costruzione che hanno bordi e punte spigolosi necessari per la funzionalità del pezzo!

Precaución
 Peligro de heridas ocasionadas por componentes puntiagudos o de cantos afilados que estén en funcionamiento!

Alle Einzelteile, insbesondere bewegliche Teile sind falls notwendig zu warten und zu reinigen.

All components, especially moving parts, should be maintained and cleaned as necessary.

Toutes les pièces détachées et en particulier les pièces mobiles, sont, si nécessaire, à entretenir et à nettoyer.

Alle onderdelen, vooral de bewegende delen, kunnen, indien noodzakelijk, onderhouden en gereinigd worden.

Es necesario limpiar y mantener en buen estado todas las diferentes piezas – especialmente las piezas móviles.

Provvedere all'occorrenza alla manutenzione e alla pulizia di tutti i particolari, specialmente le parti mobili.

Discovery Racer



1

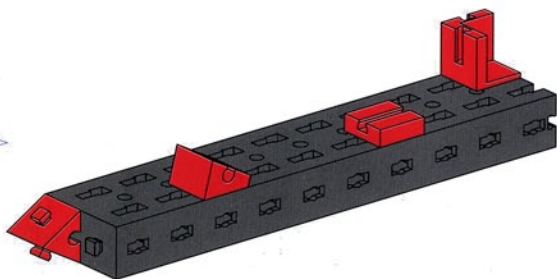
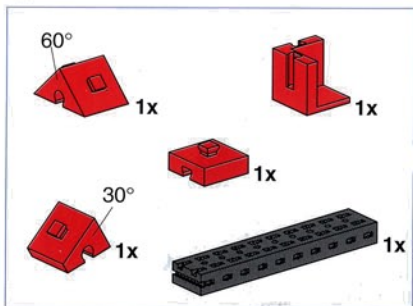

2

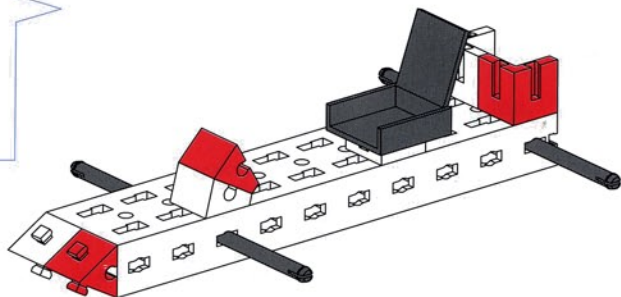
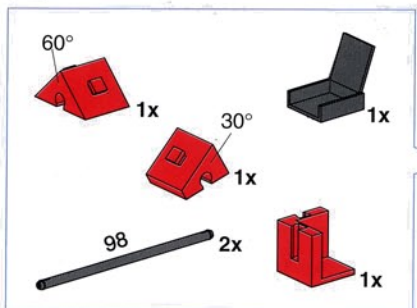

3

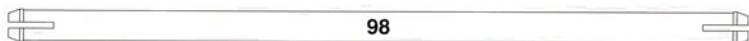
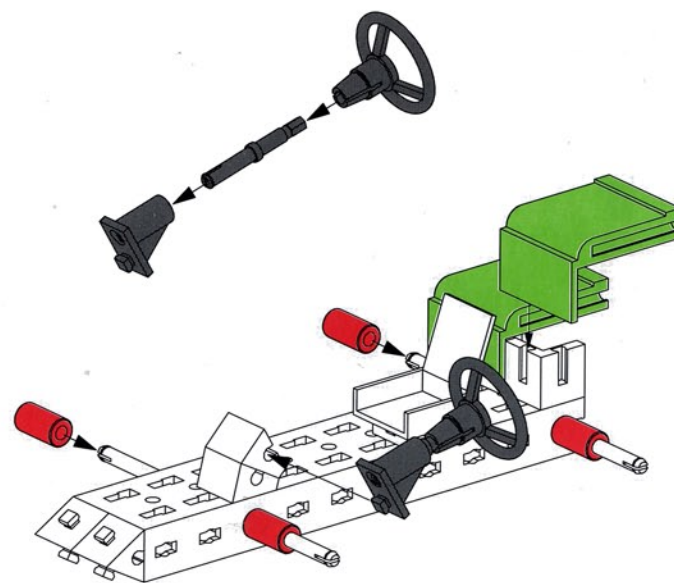
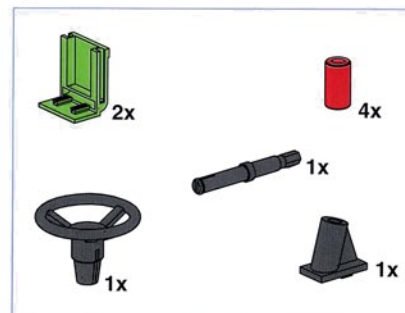

4

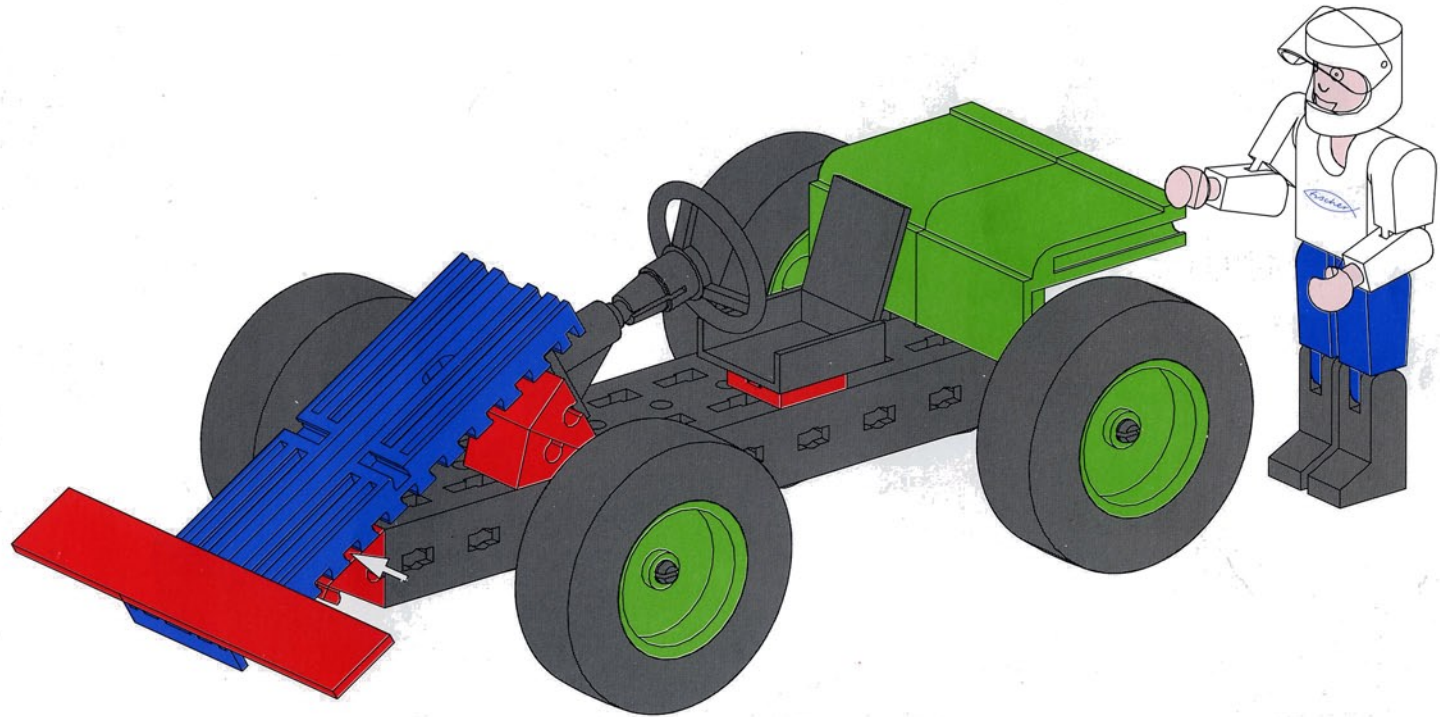
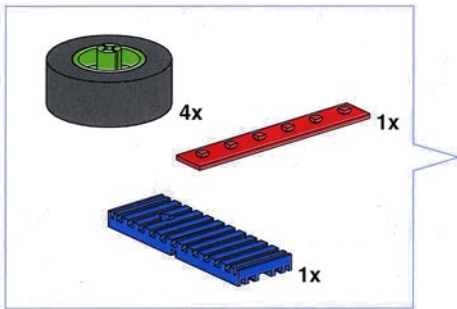

Mountain JEEP

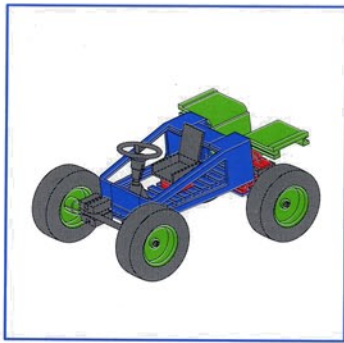

1

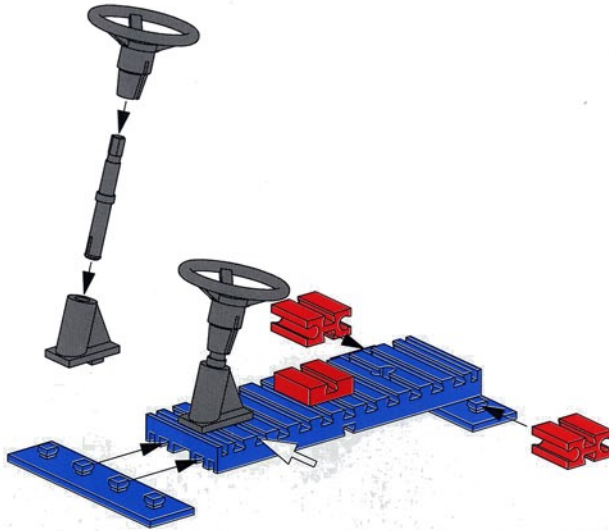
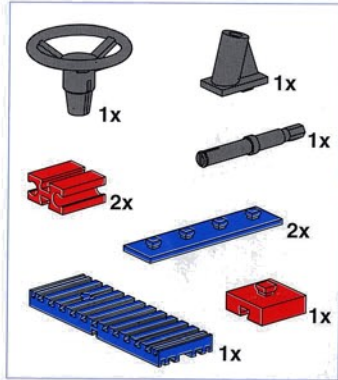

2

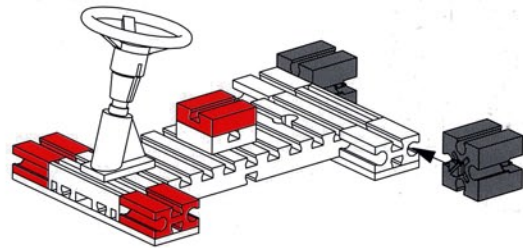
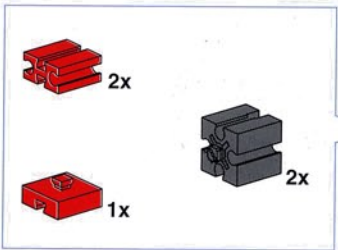

3

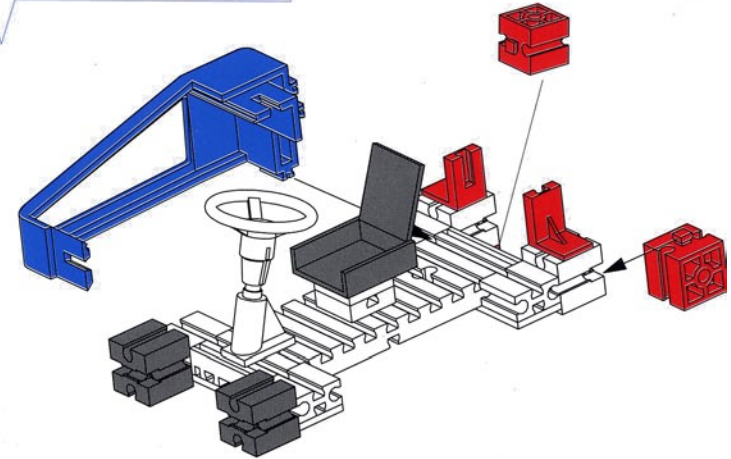
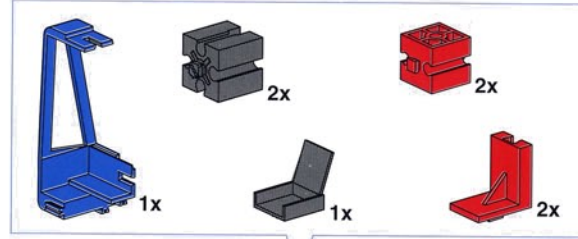

4

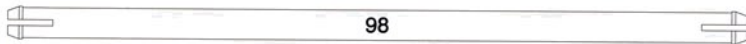
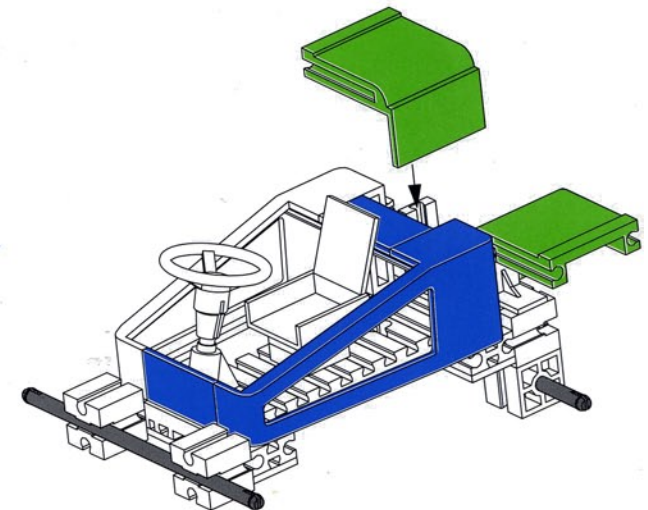
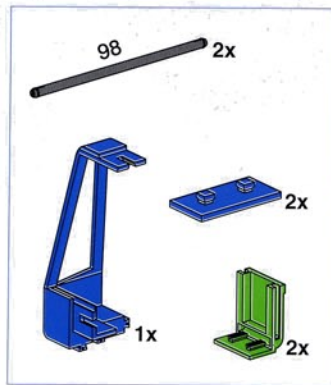

5

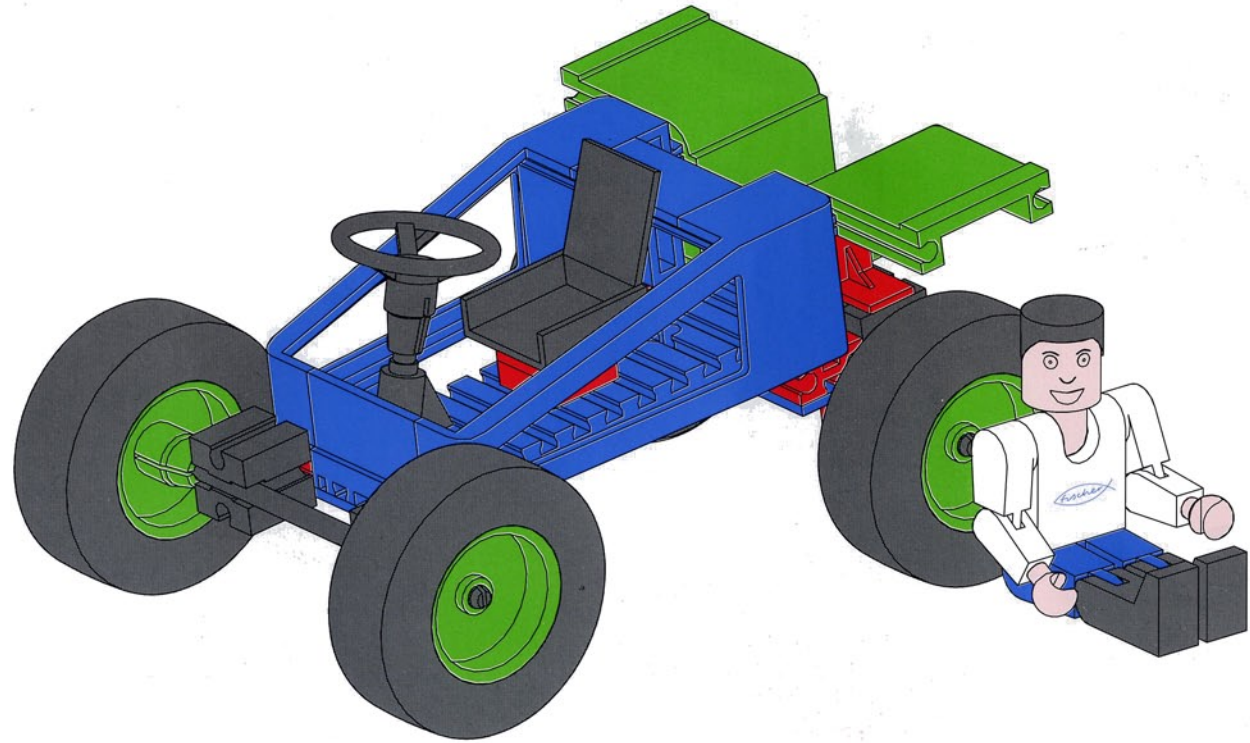
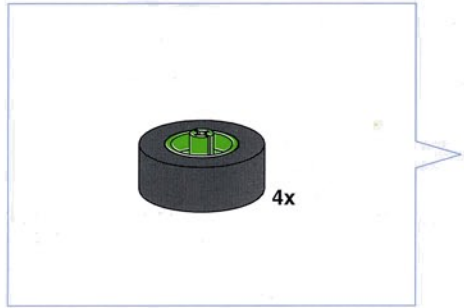

Beach Buggy



1

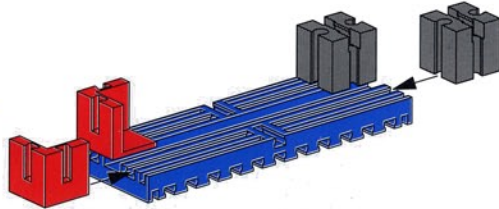
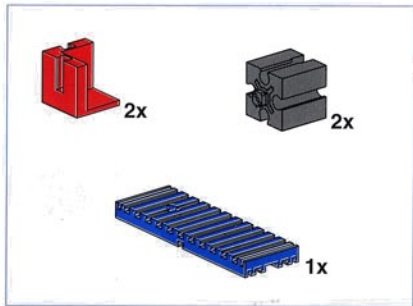

2

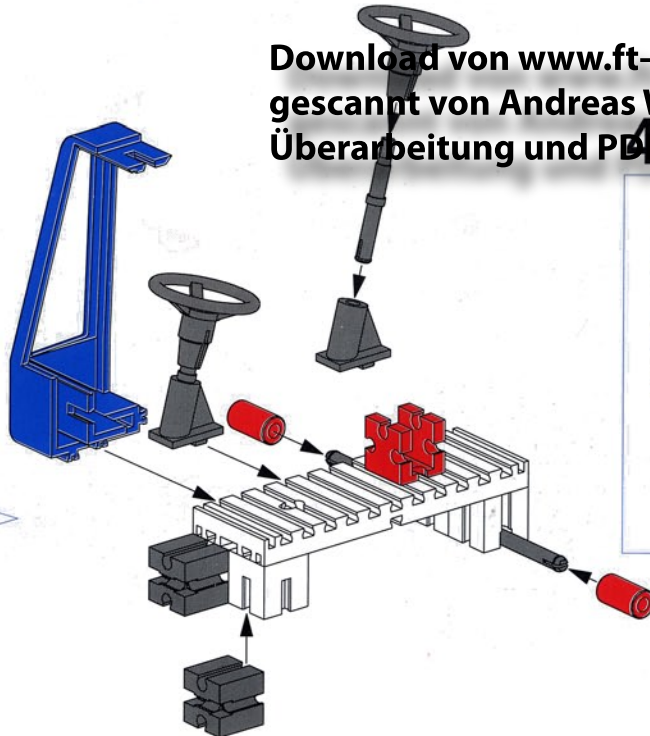
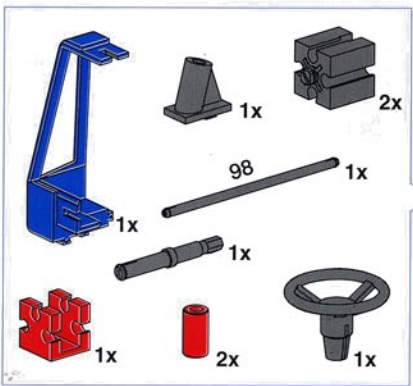

3

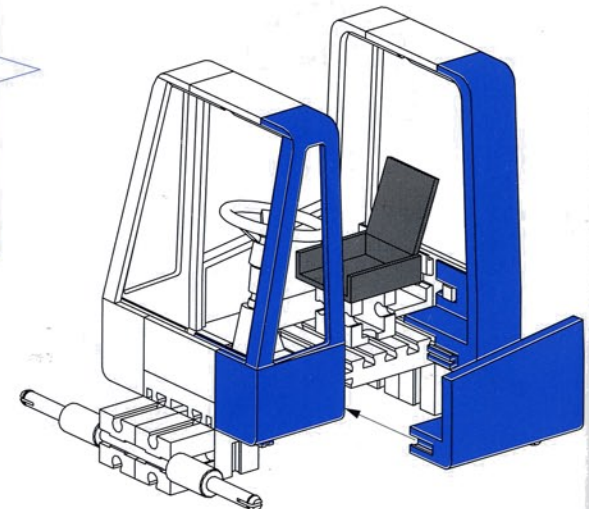
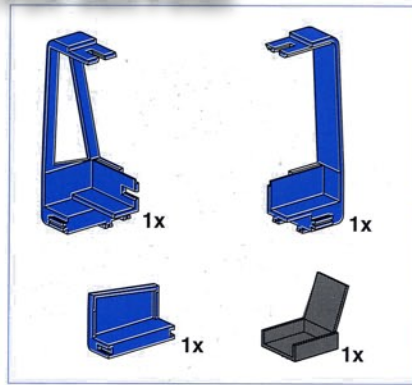
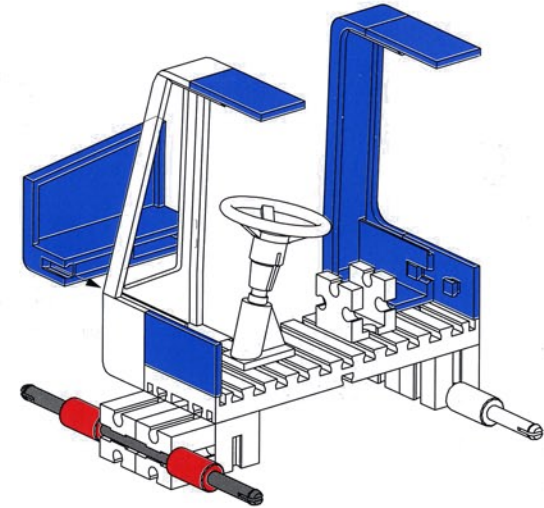
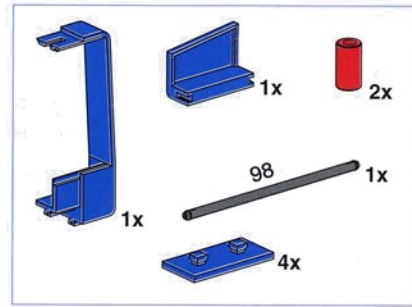

Download von www.ft-fanarchiv.de
gescannt von Andreas Wyrobek
Überarbeitung und PDF von Peter



98

5

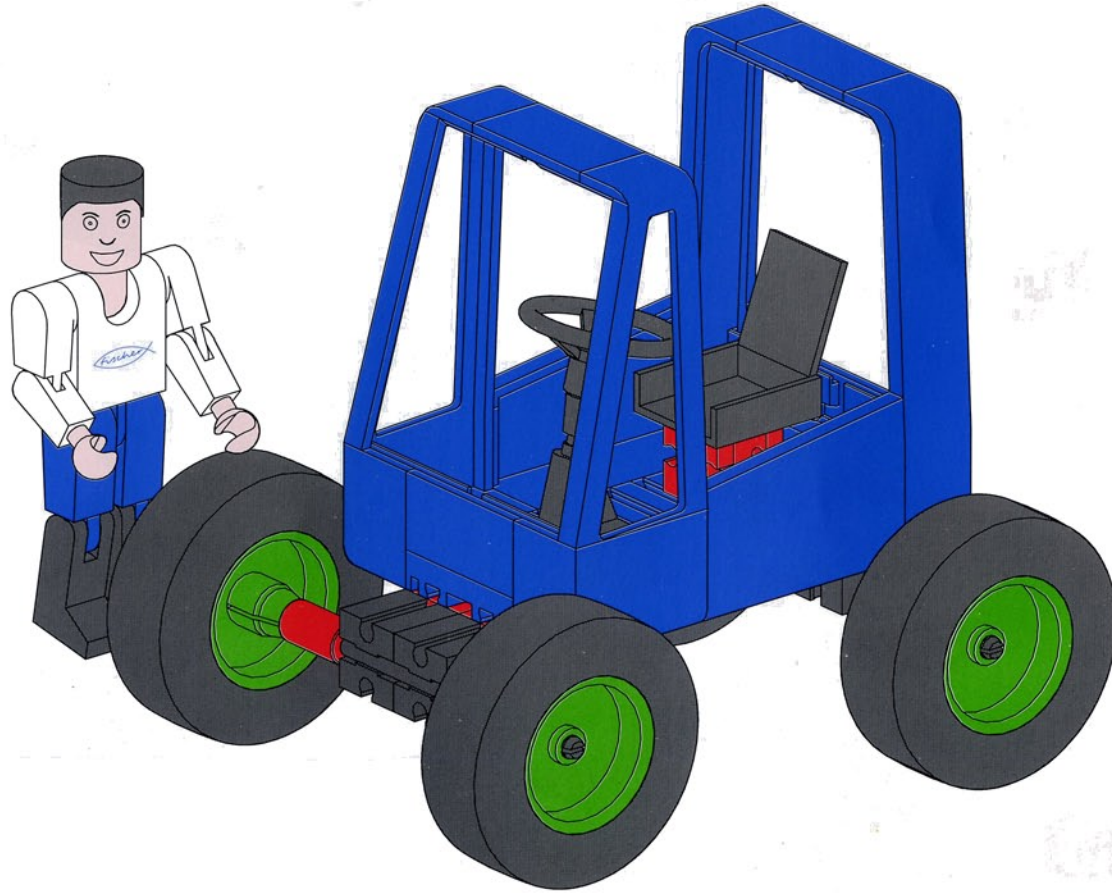
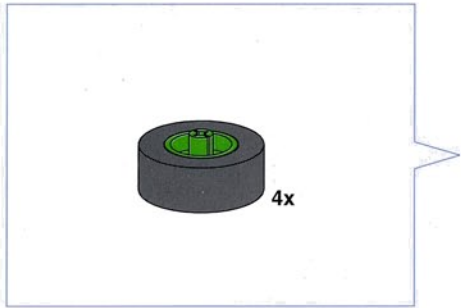

Snow Cat

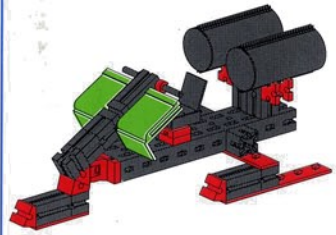

1

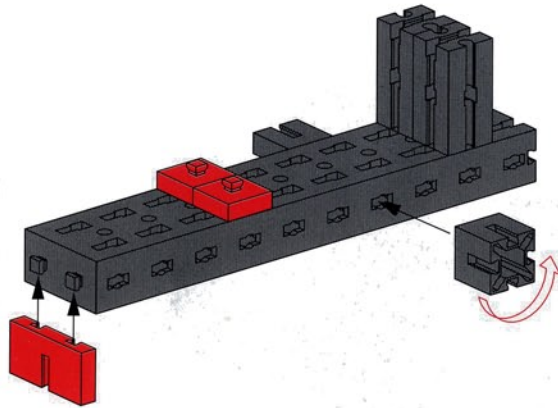
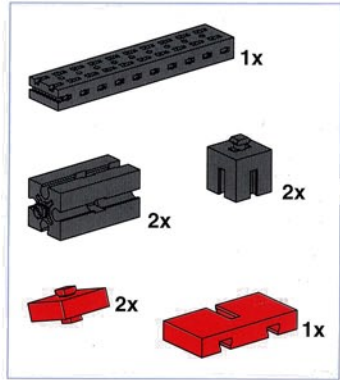

2

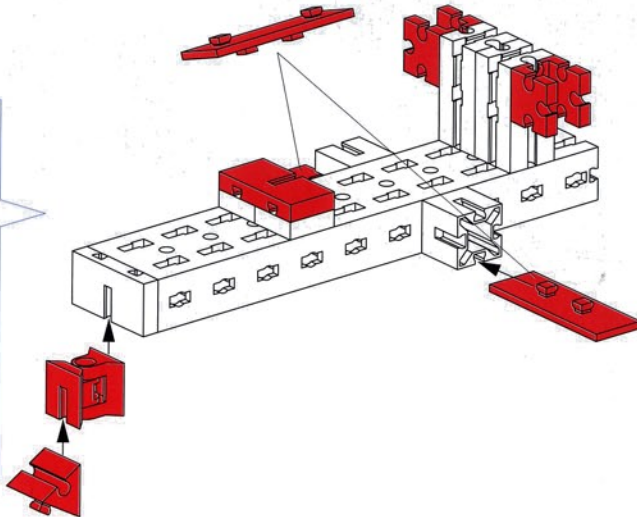
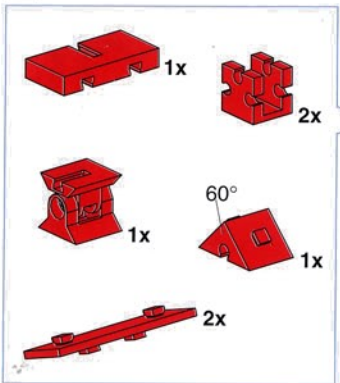

3

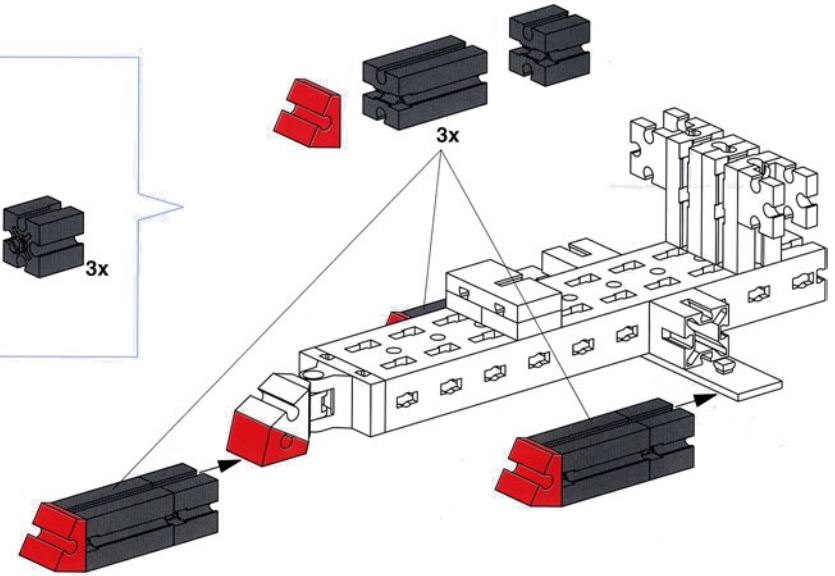
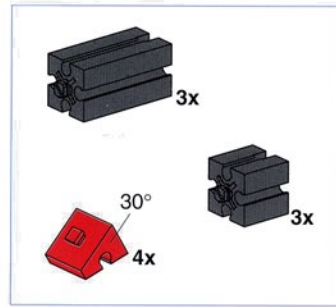

4

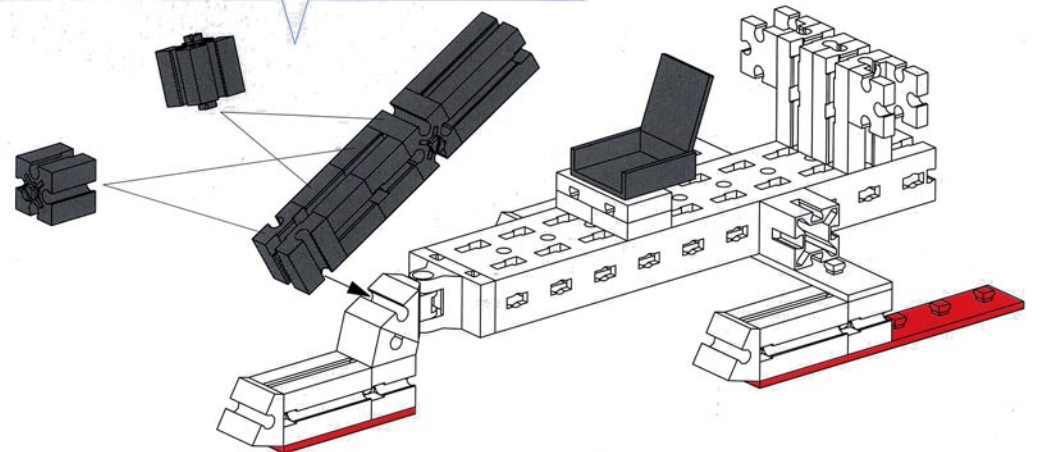
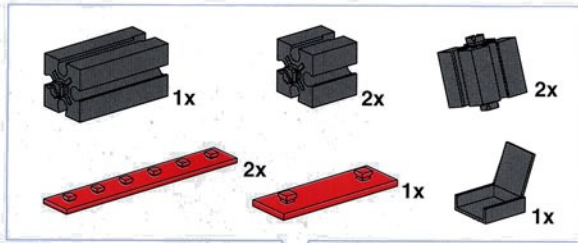

5

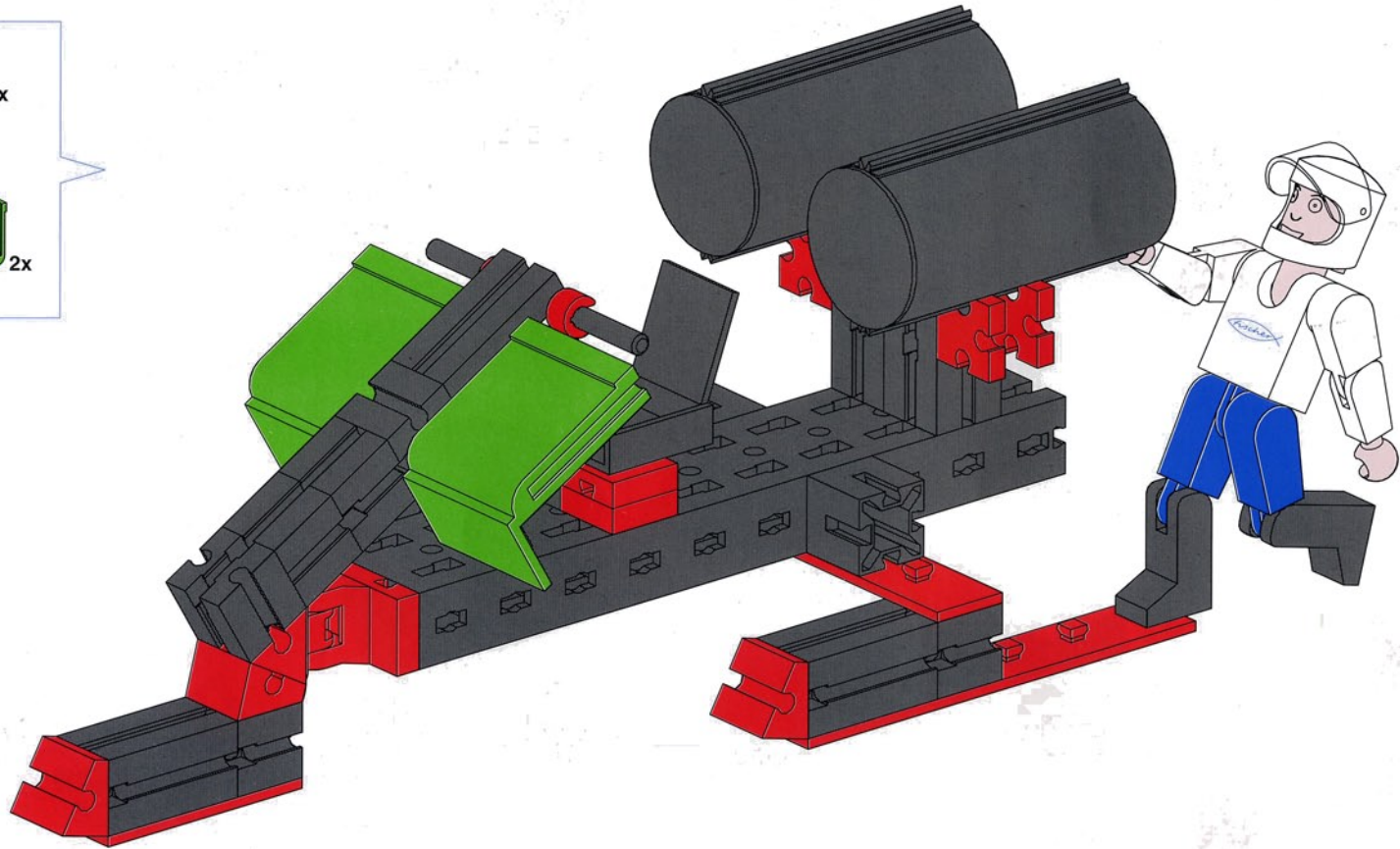
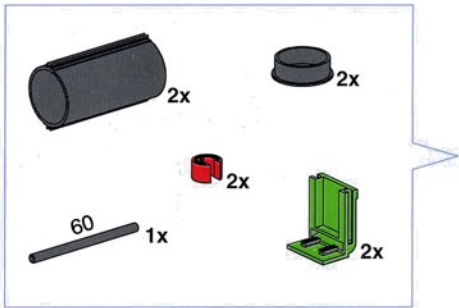

Ice Patroller

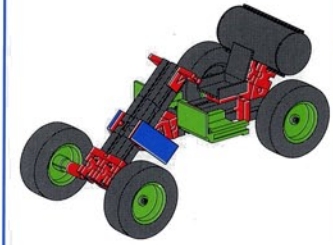

1

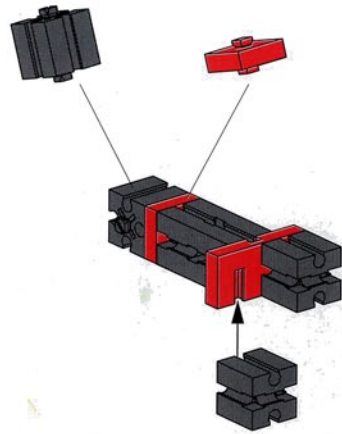
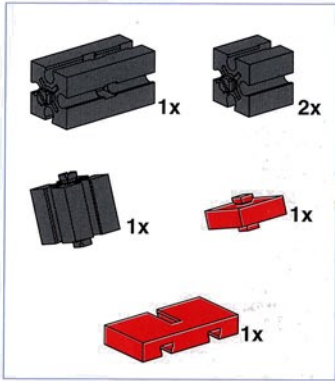

2

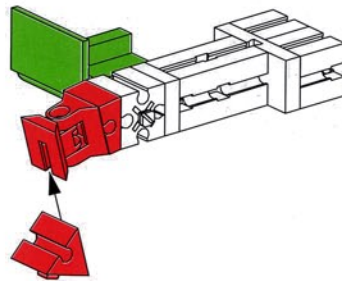
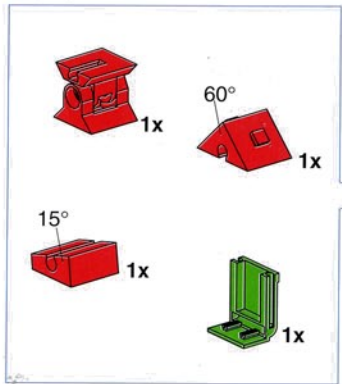

3

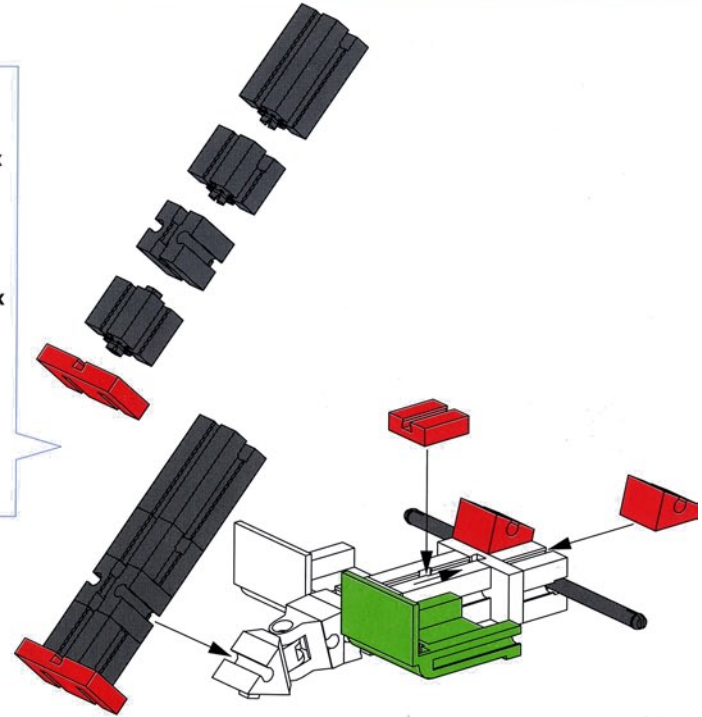
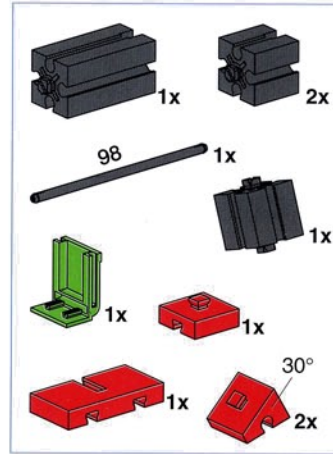

4

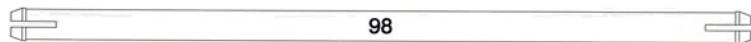
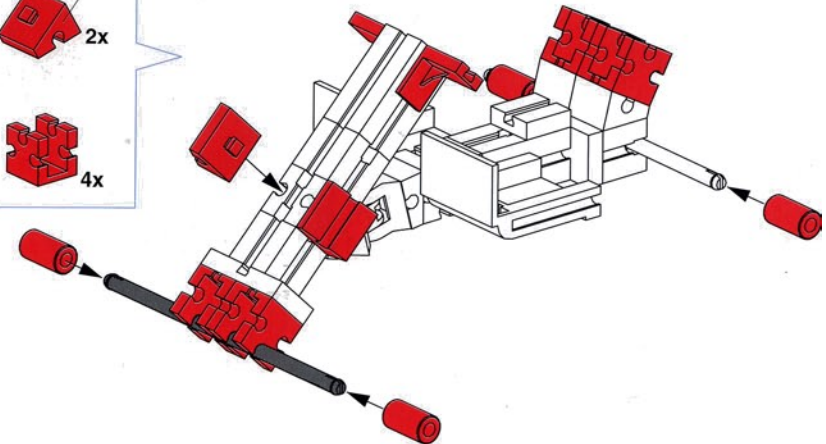
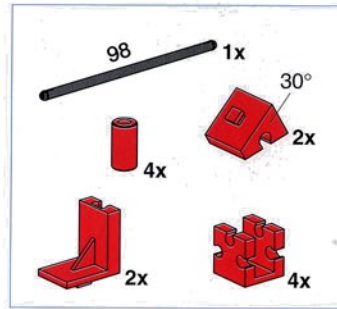

5

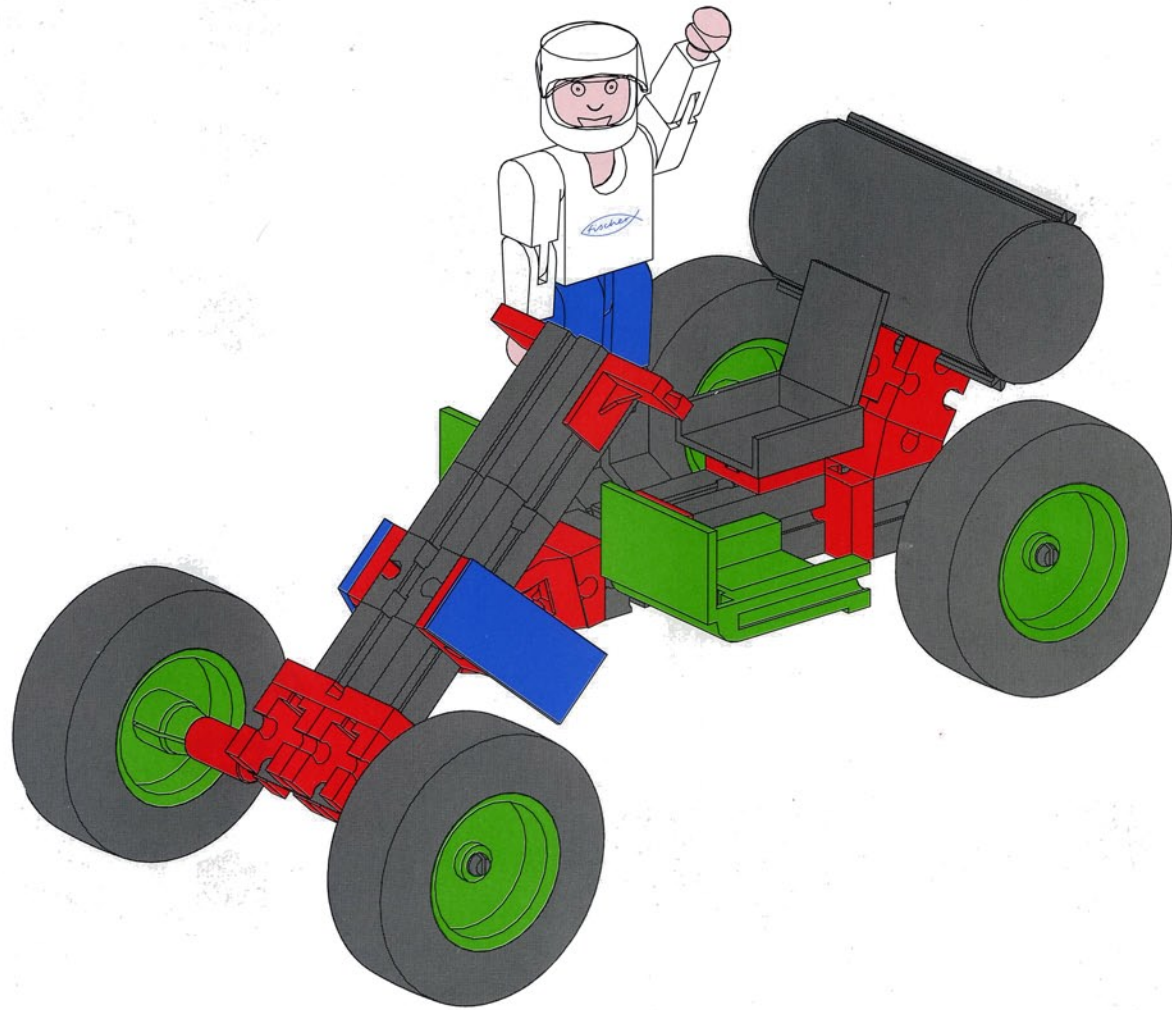
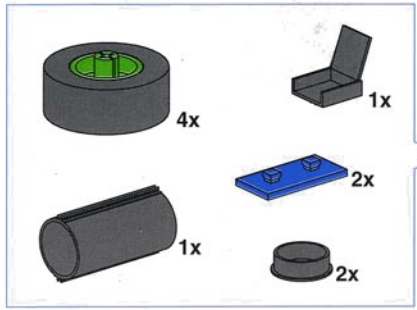

Canyon Explorer

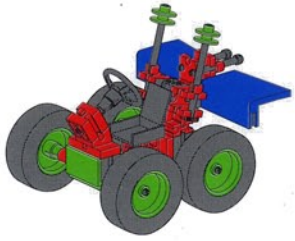

1

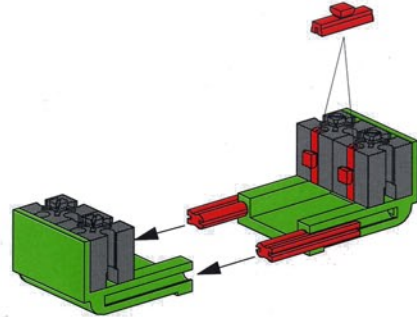
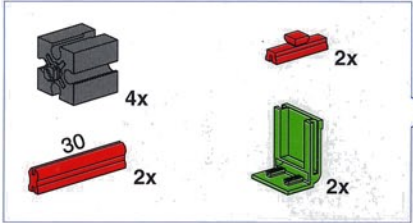

3

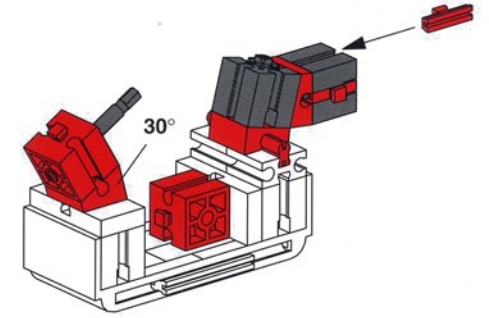
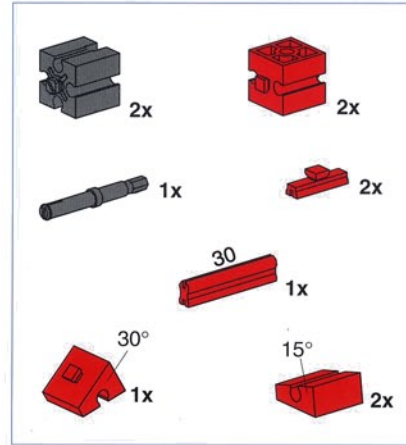

2

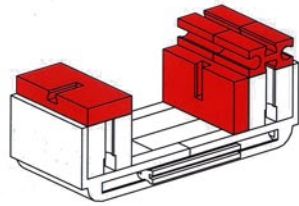
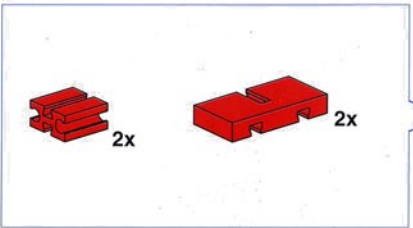

4

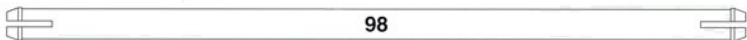
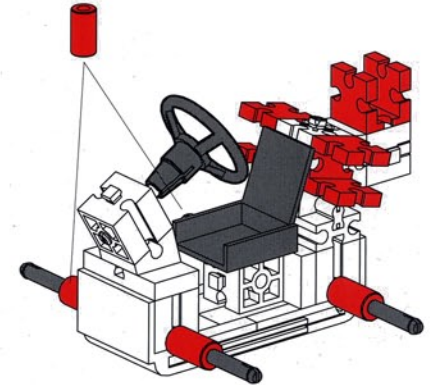
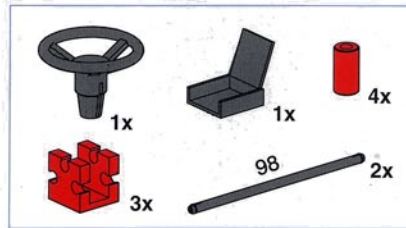

98

5

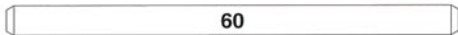
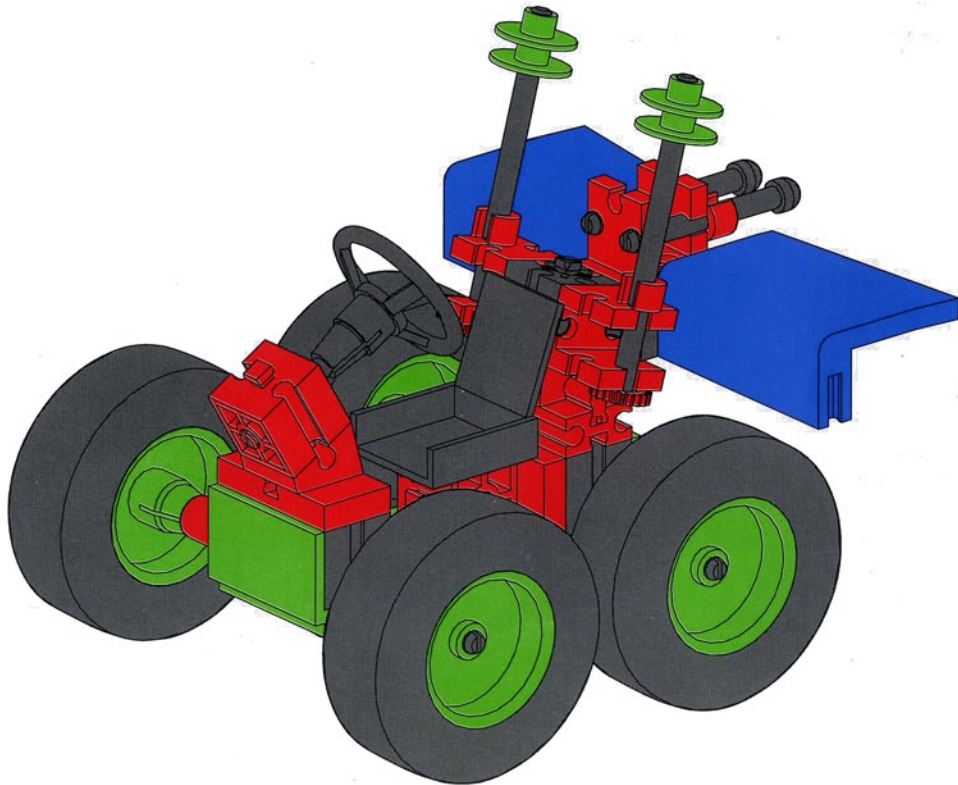
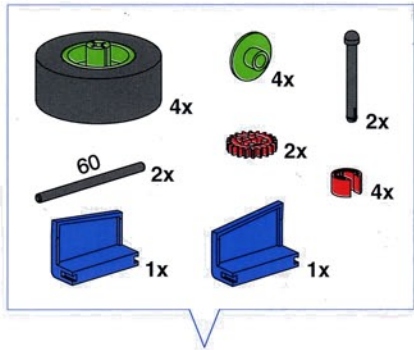

1

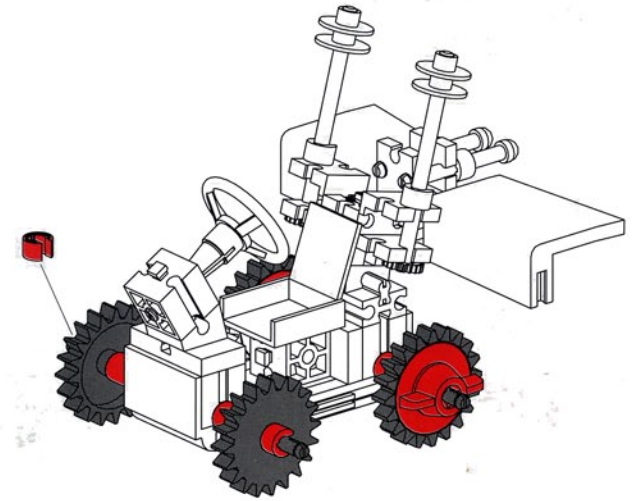
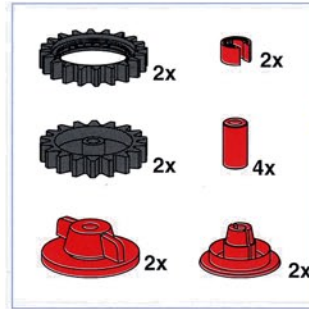

2

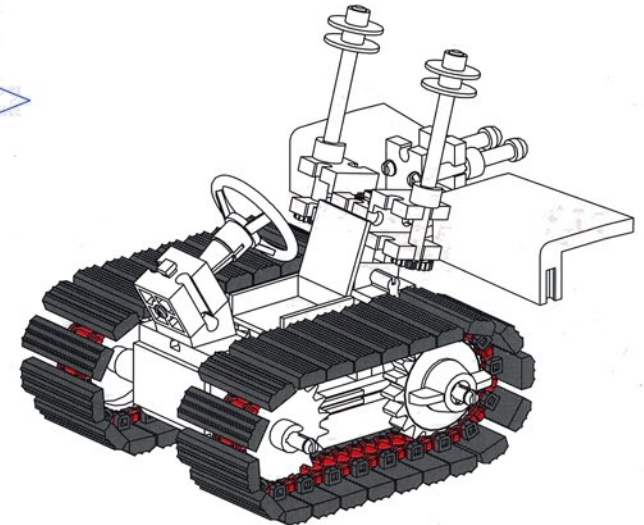
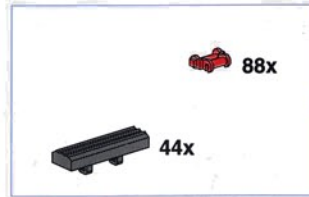

Moon Racer



1

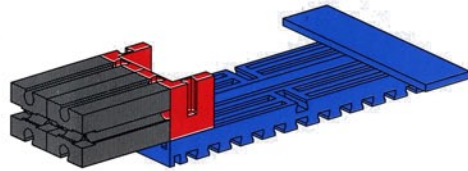
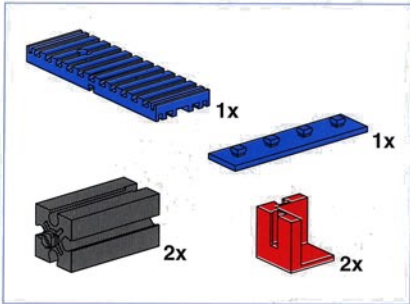

2

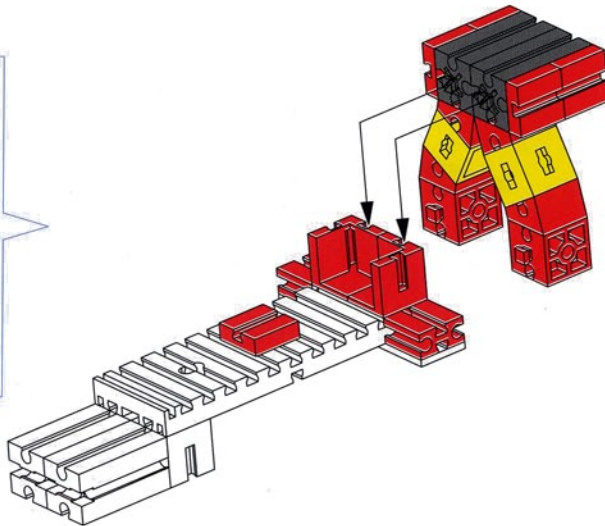
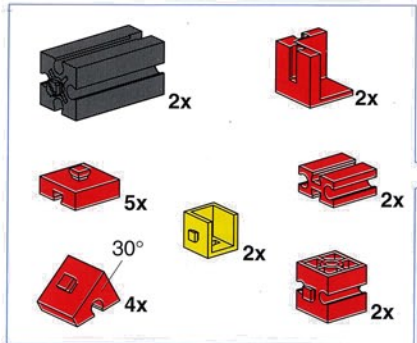



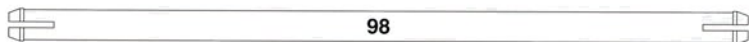
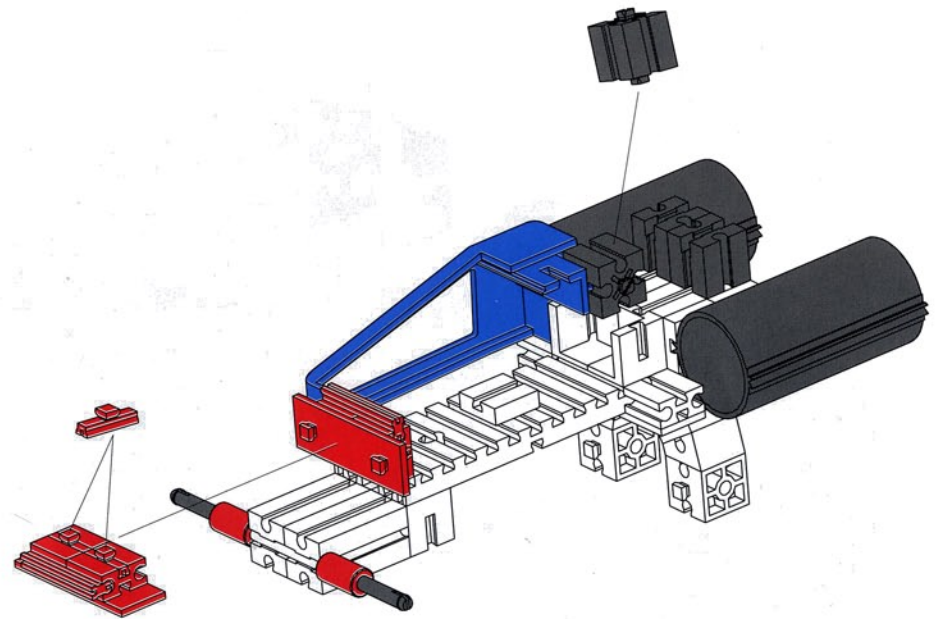
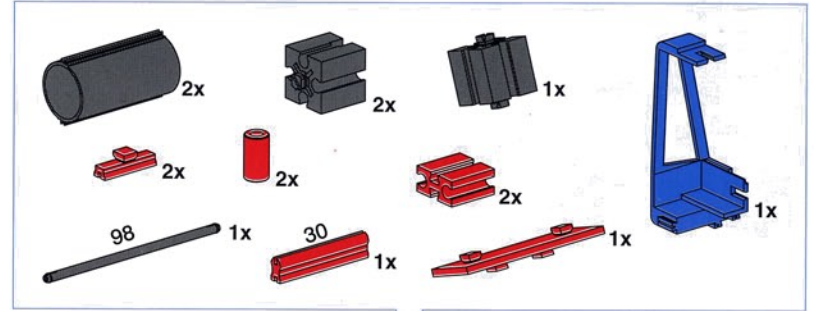















3



98

4

- 4x 
- 1x 
- 1x 
- 2x 
- 110 
- 2x 
- 1x 
- 1x 
- 1x 
- 1x 
- 2x 
- 2x 
- 2x 
- 1x 
- 2x 
- 2x 
- 2x 
- 1x 
- 1x 

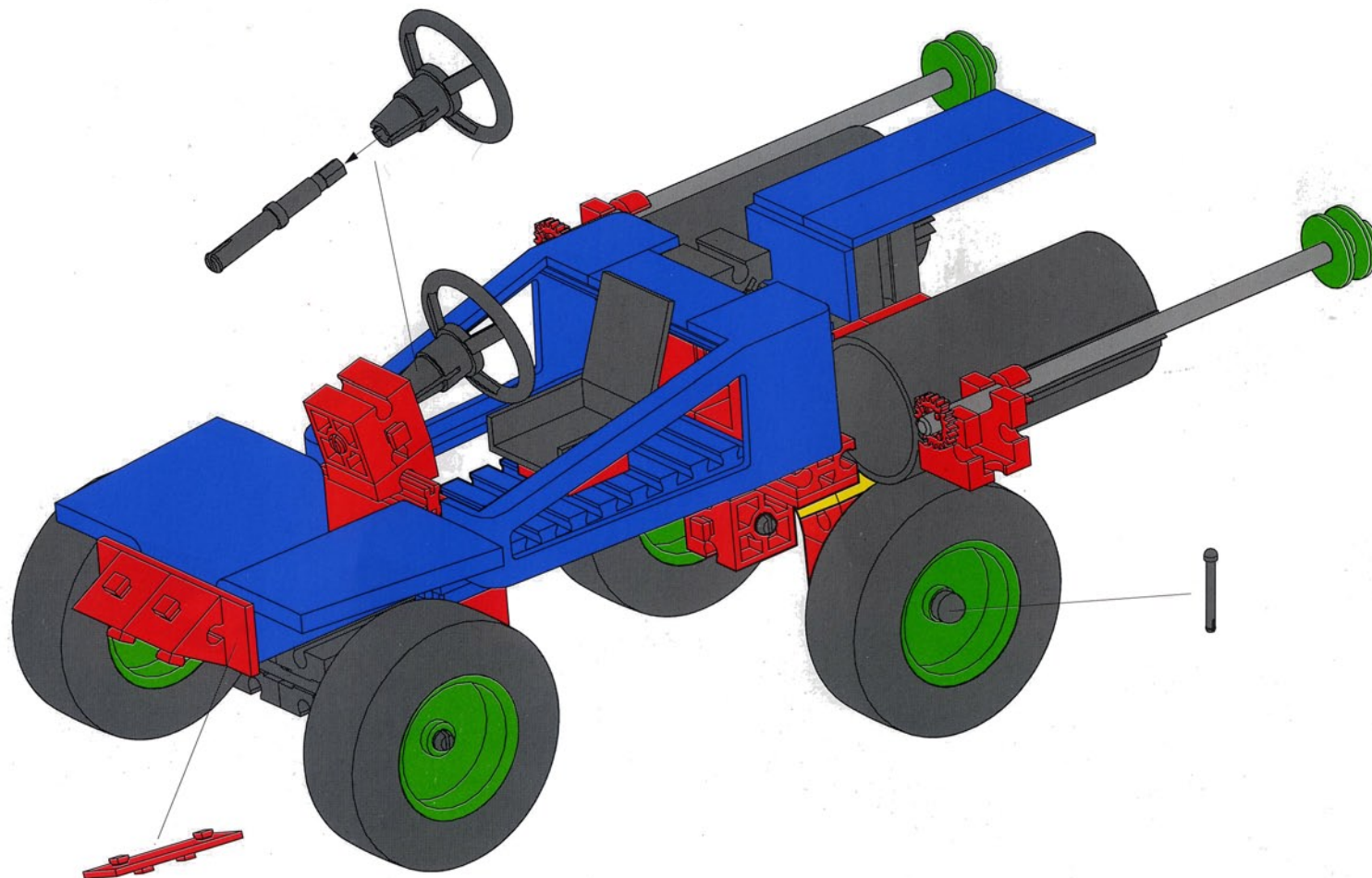

Freight Truck

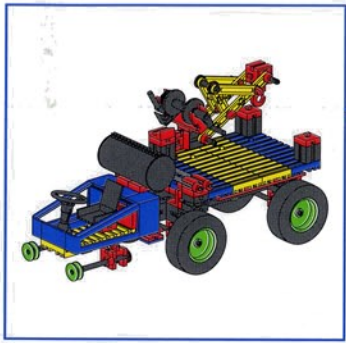

1

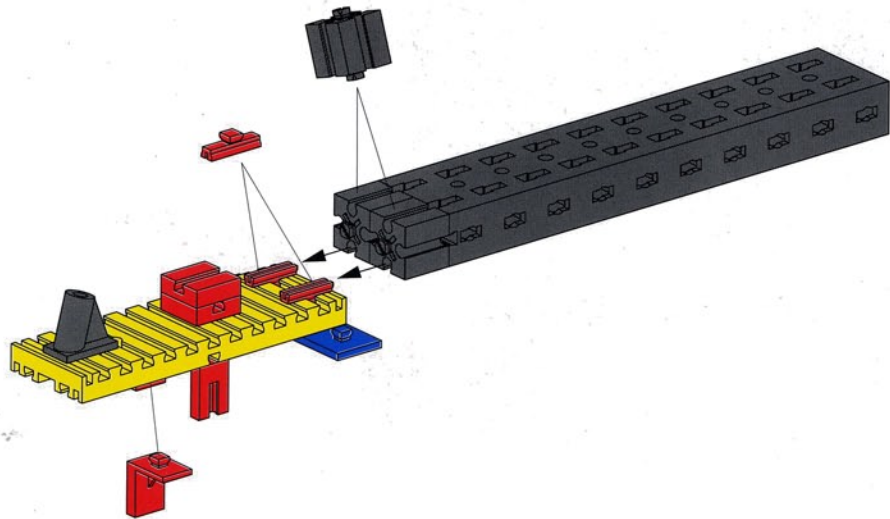
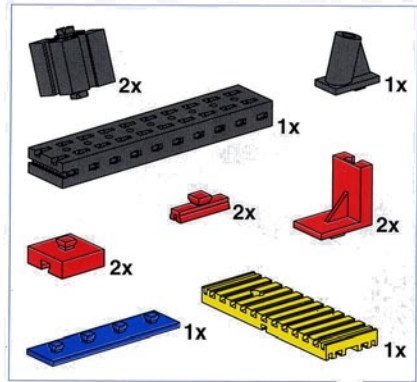

2

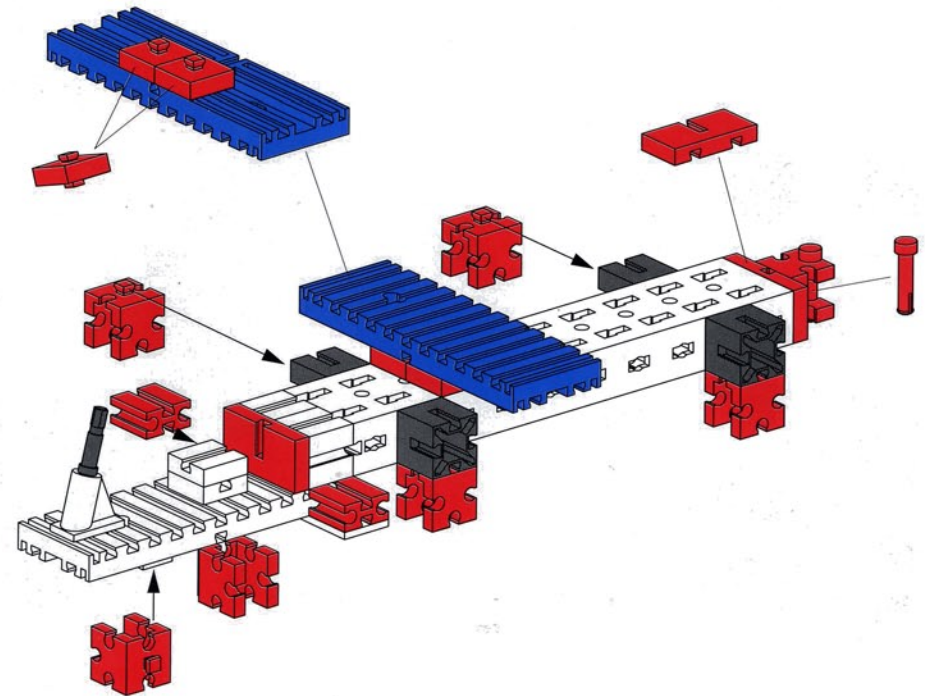
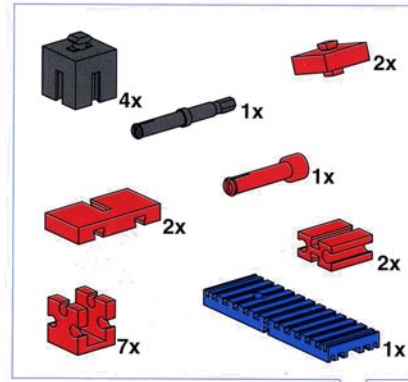



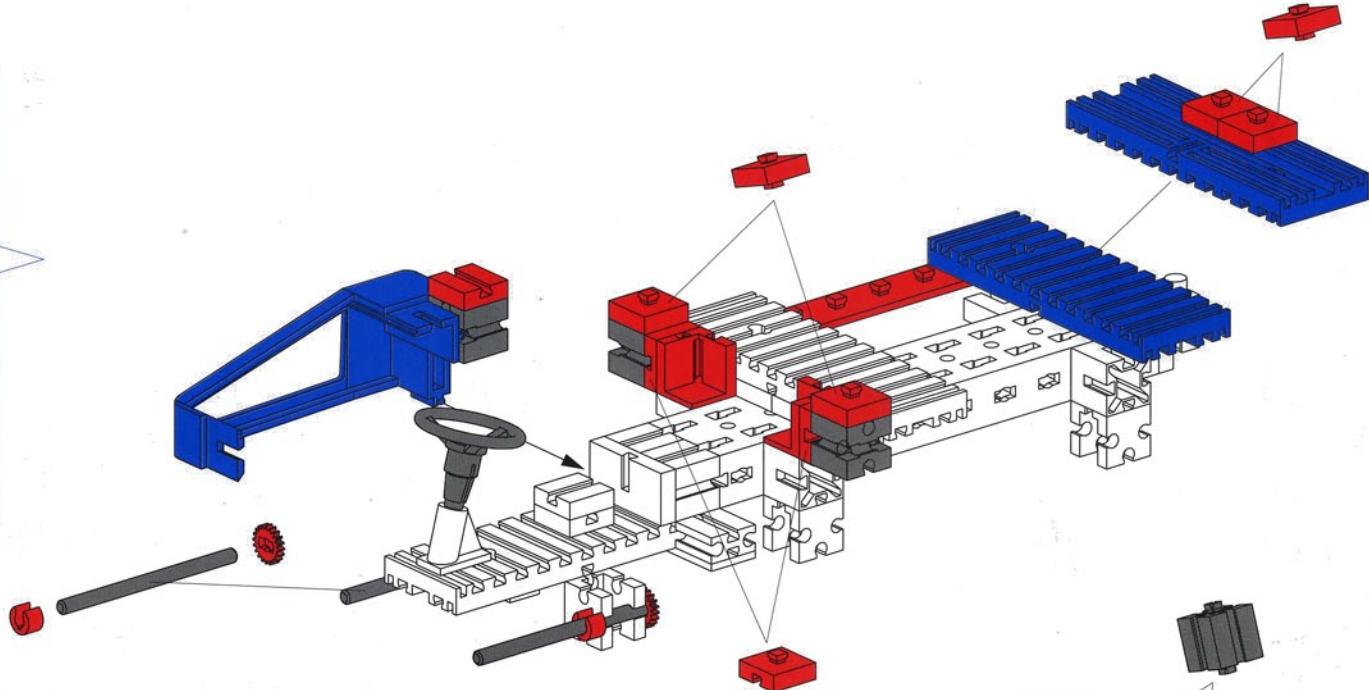
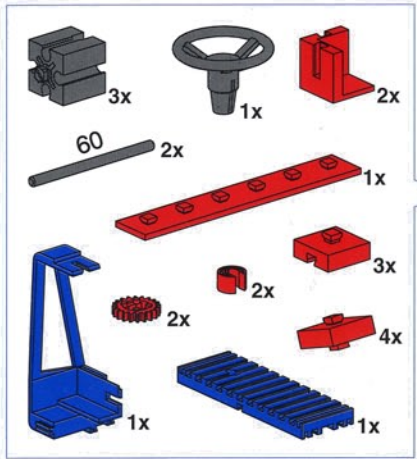



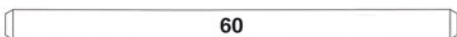
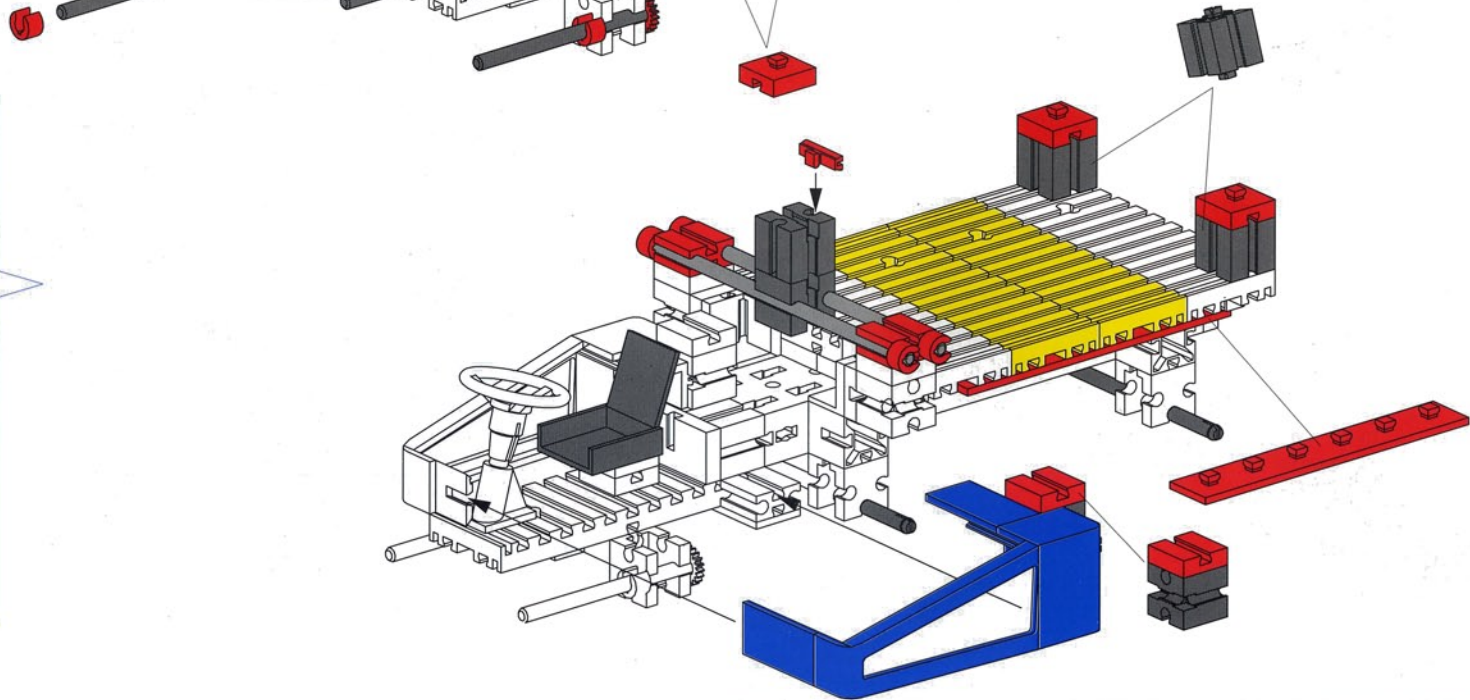
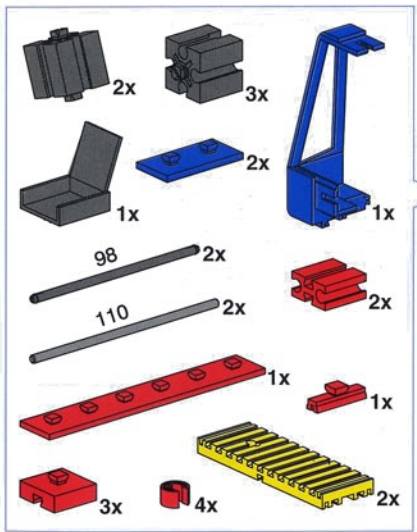









3



4







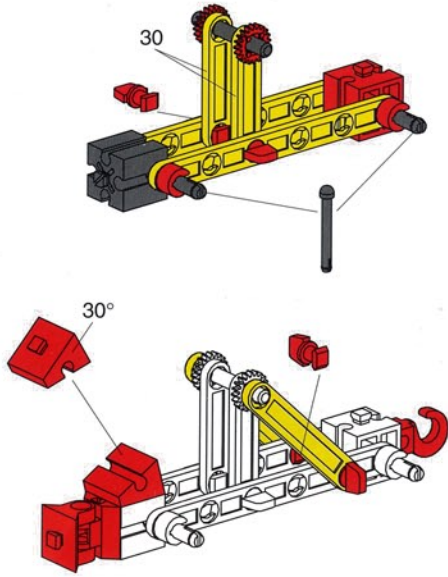

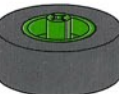

5

-  1x
-  1x
-  1x
-  1x
-  2x
-  1x
-  2x
-  30
-  30
-  42.4
-  75
-  2x
-  4x
-  30
-  30
-  42.4
-  75



6

-  4x
-  1x
-  2x
-  1x
-  15°
-  1x
-  1x
-  1x

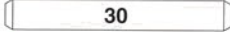
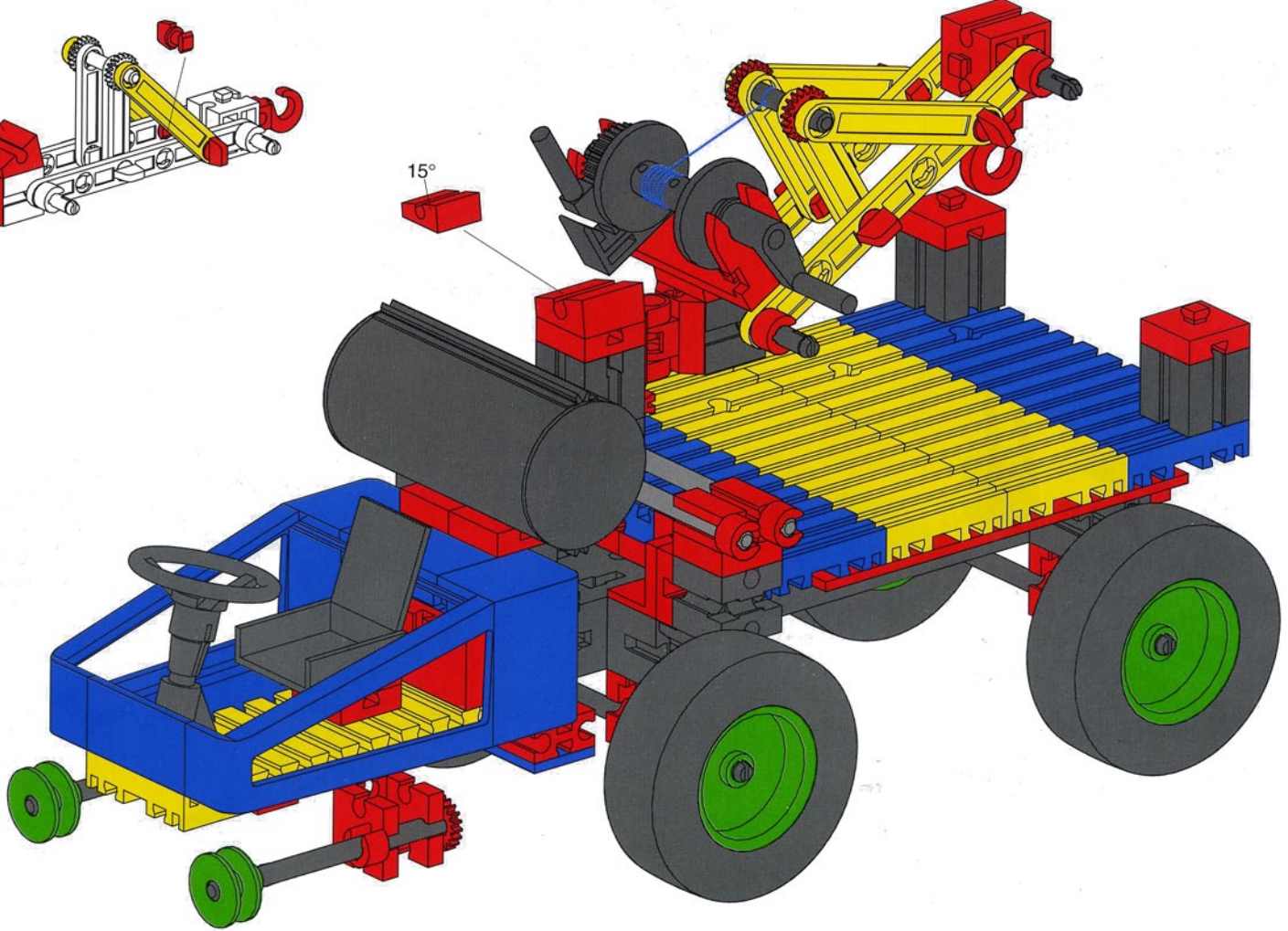

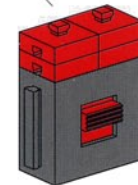
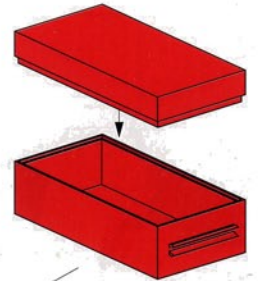
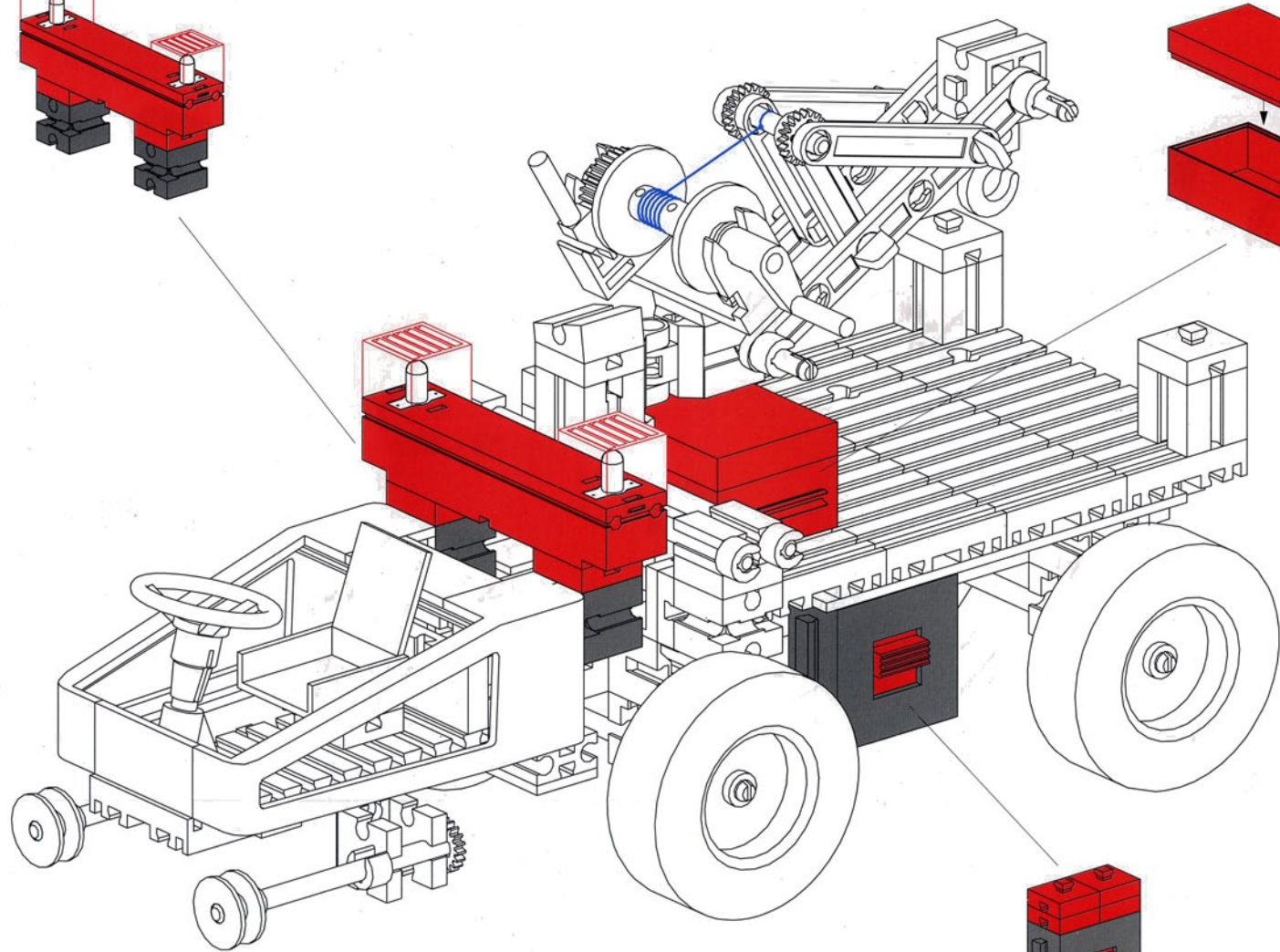
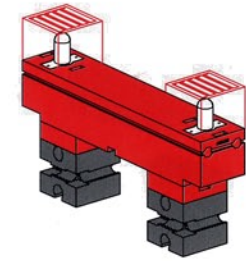
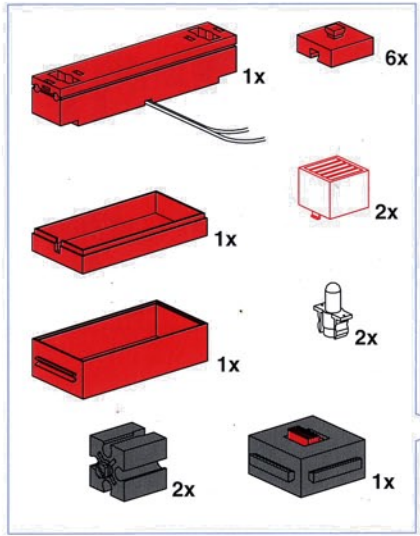

Crane Truck

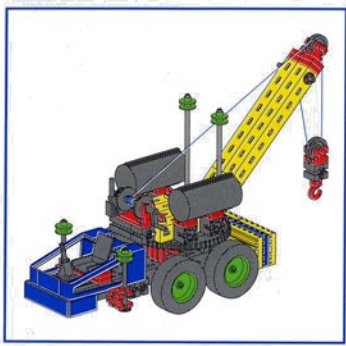

1

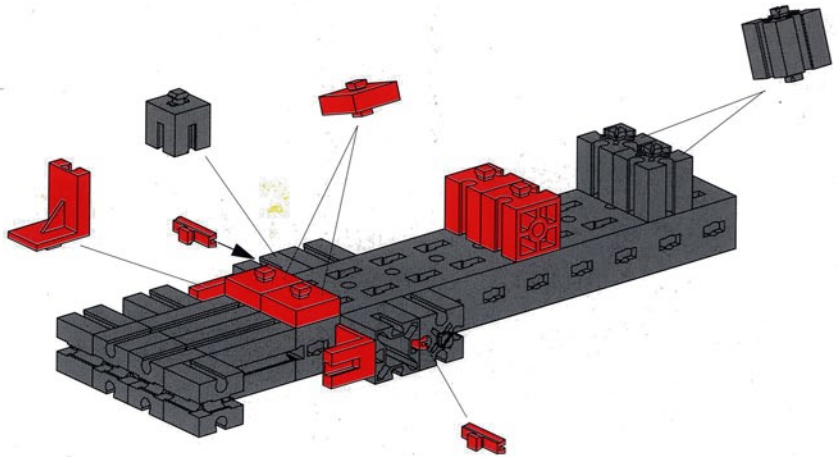
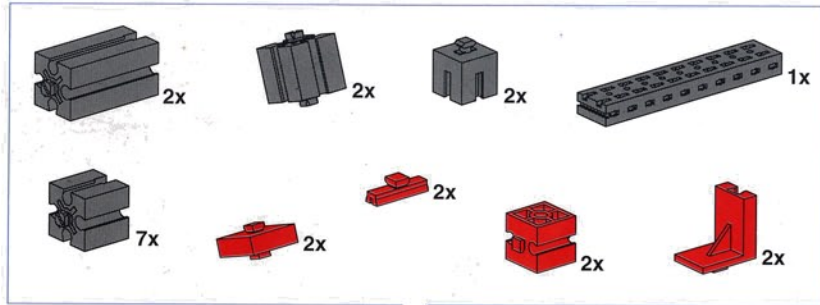

2

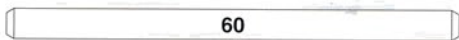
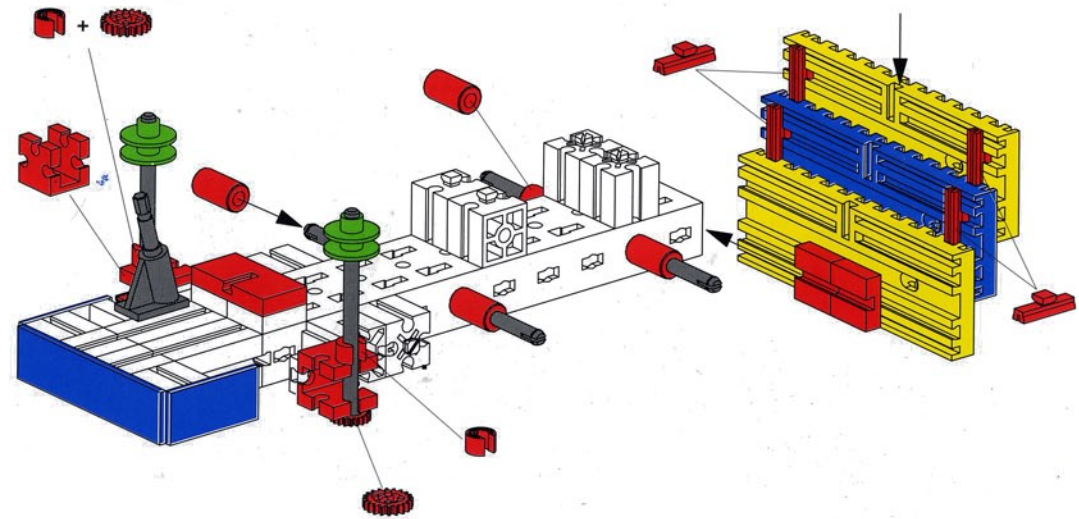
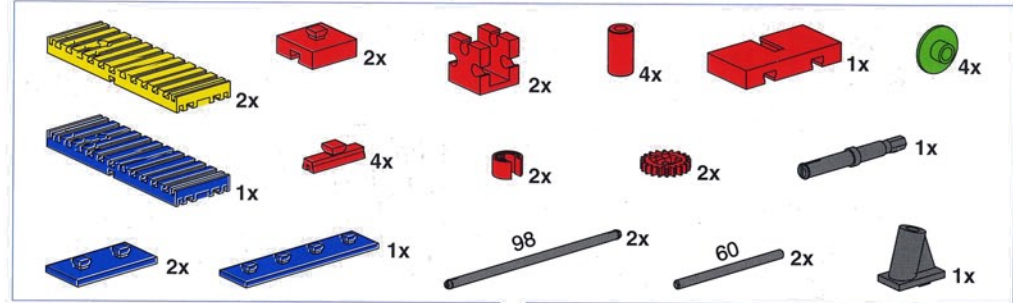

60

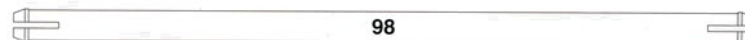

98

3

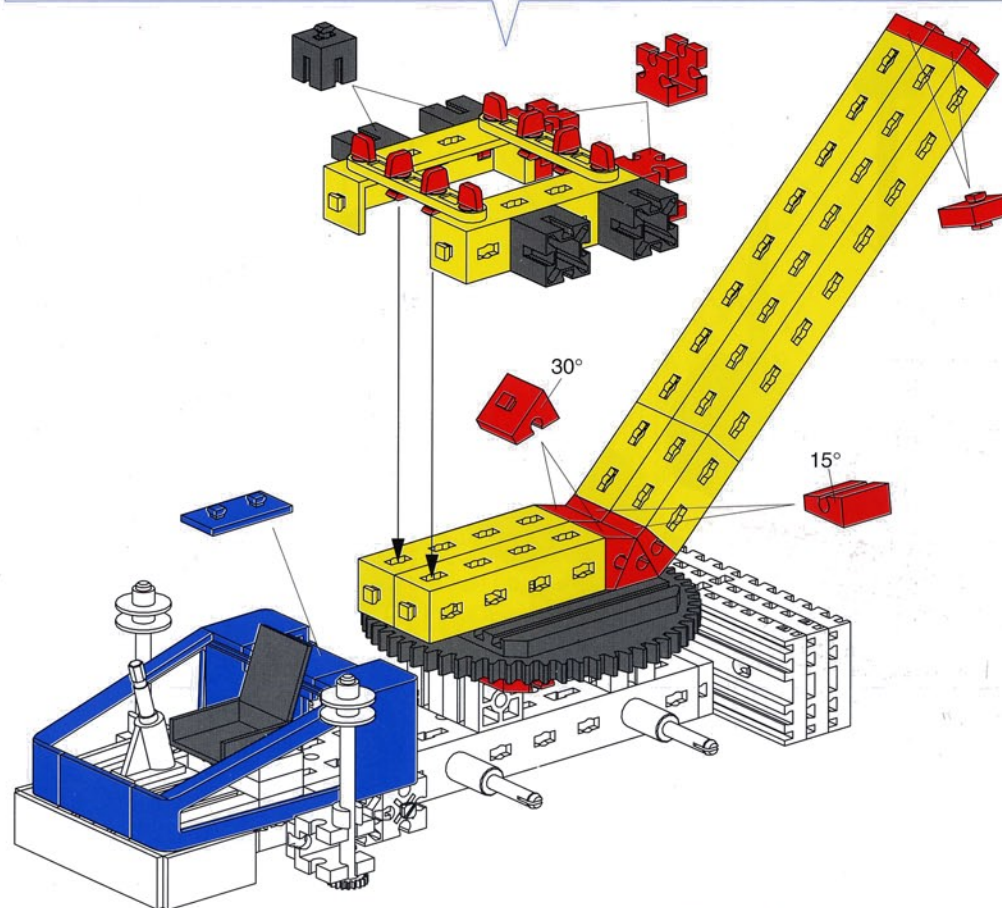
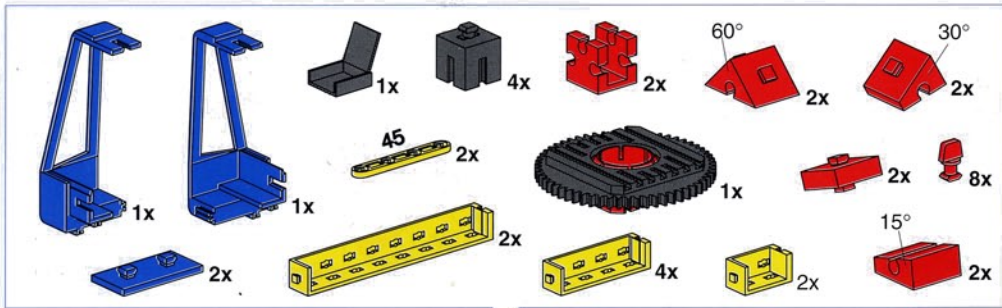

110

4

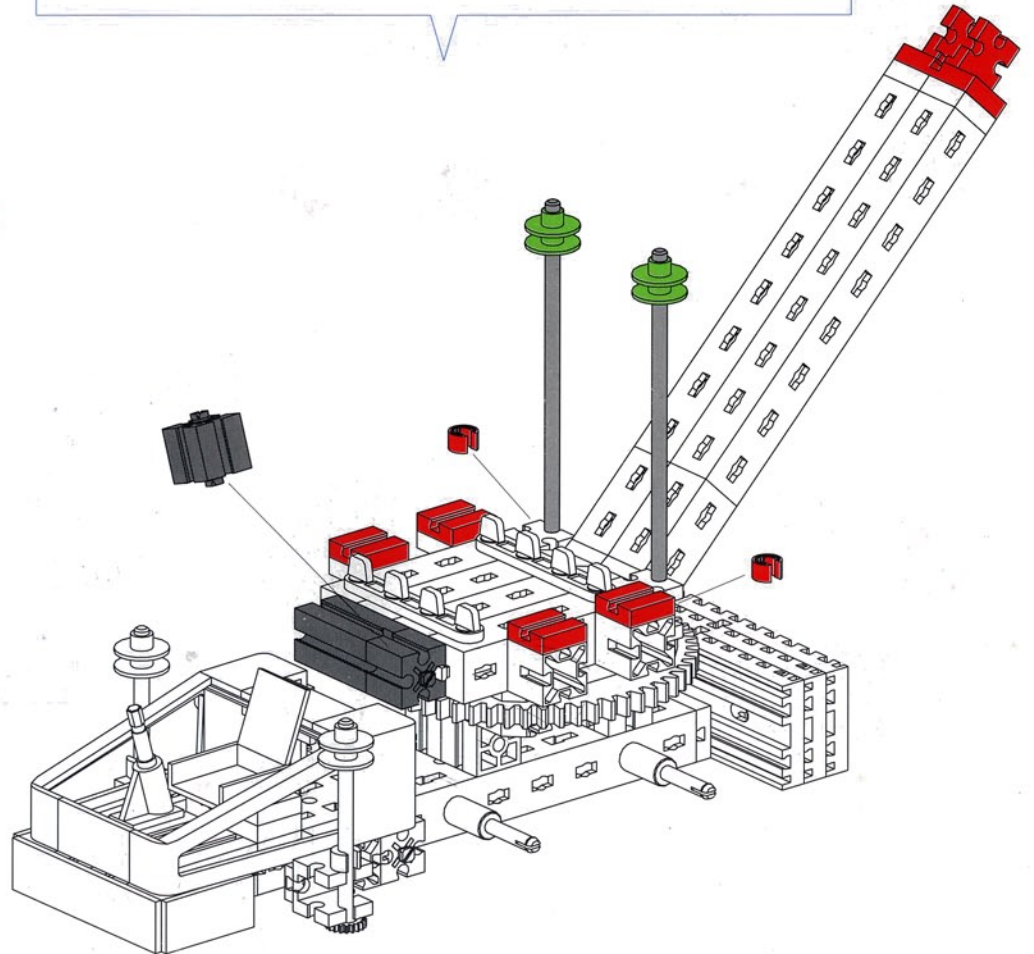
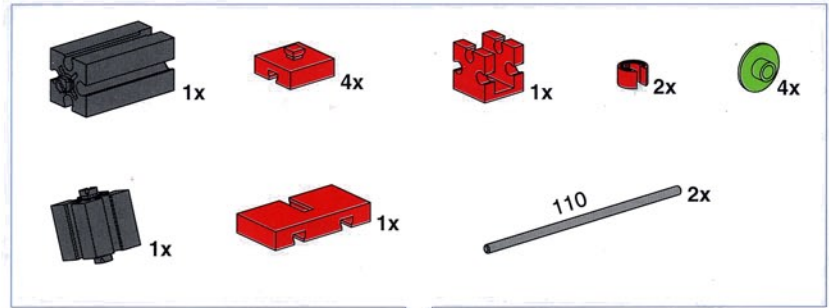

5

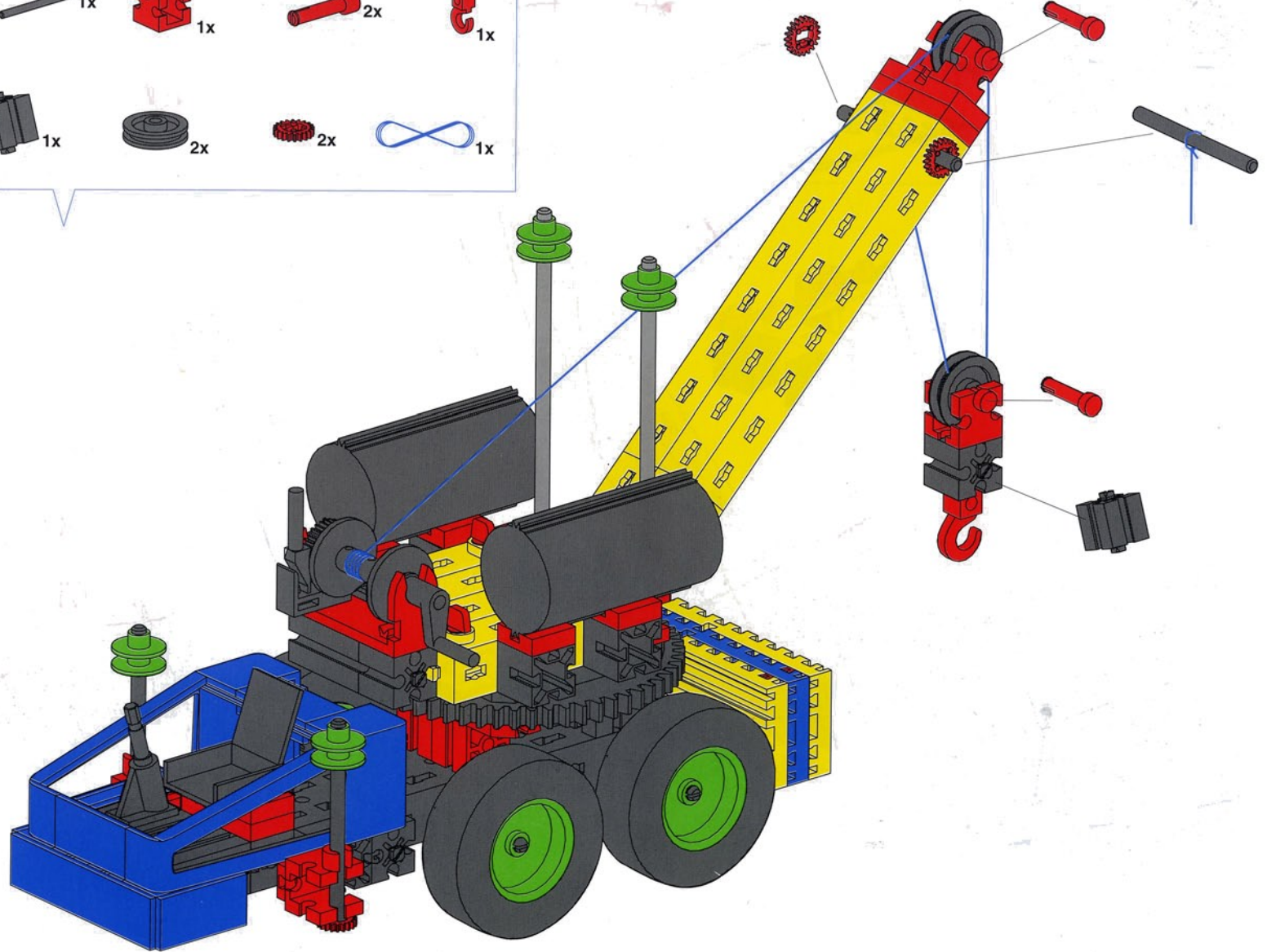
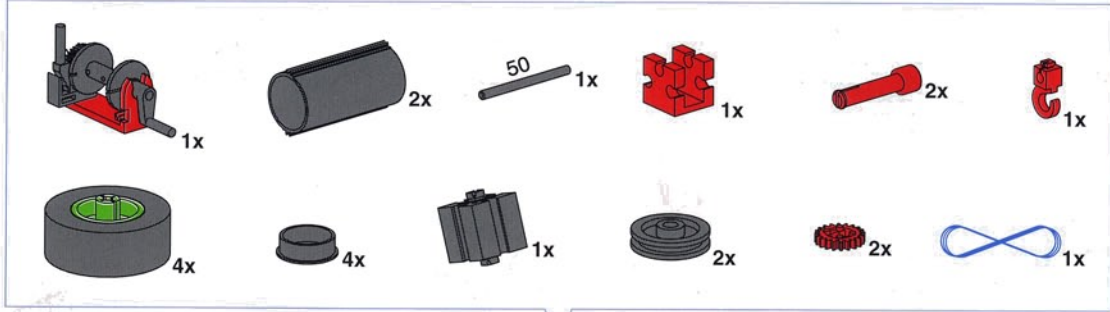

50

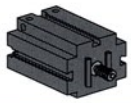

1

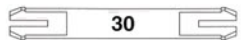
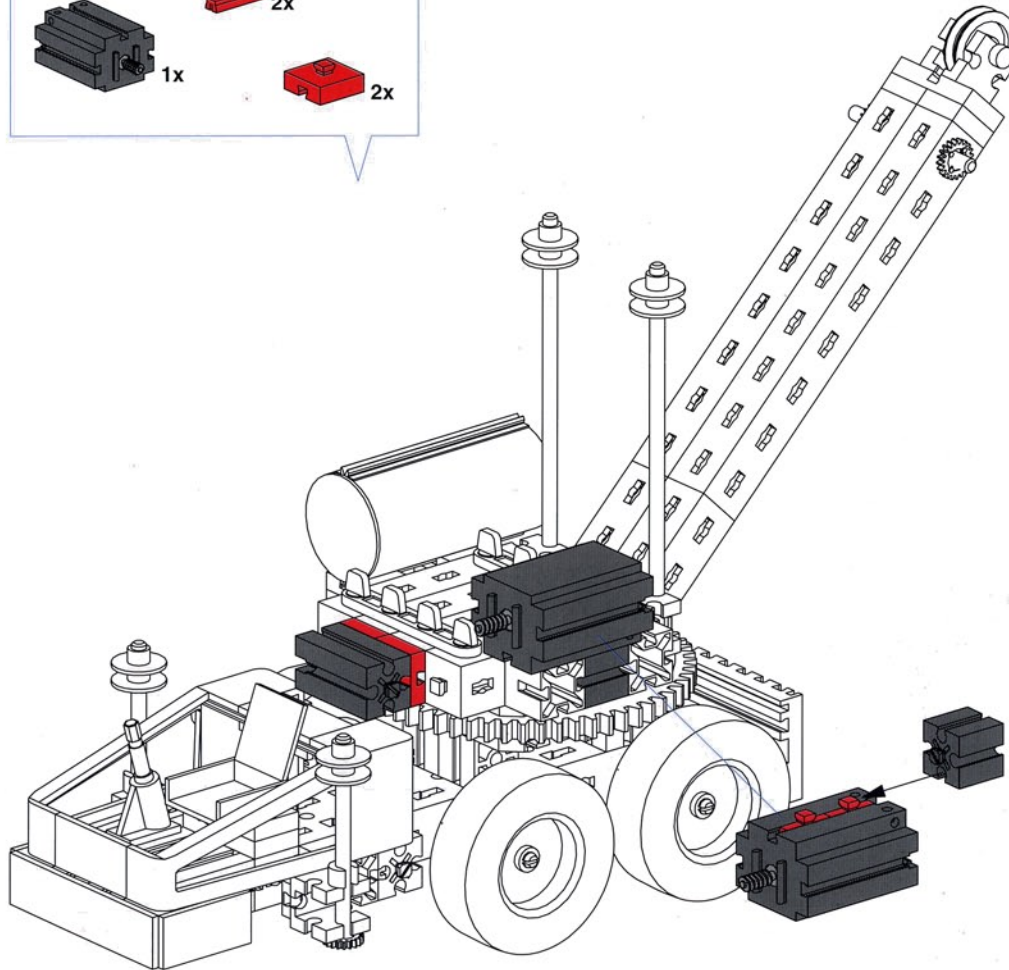
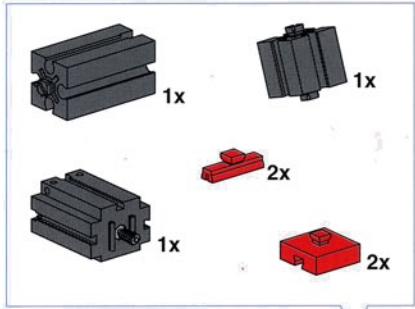

2

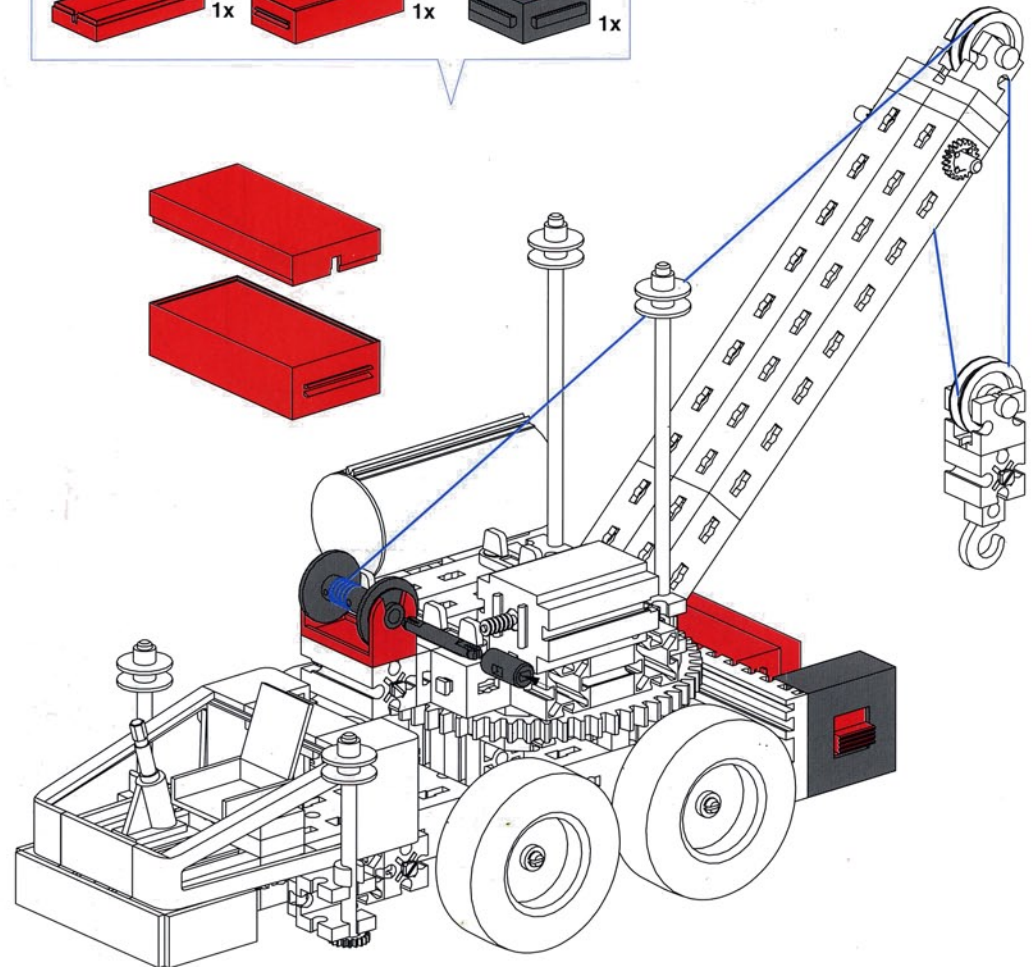
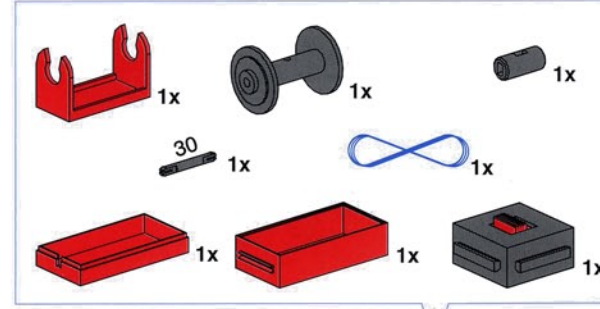

3

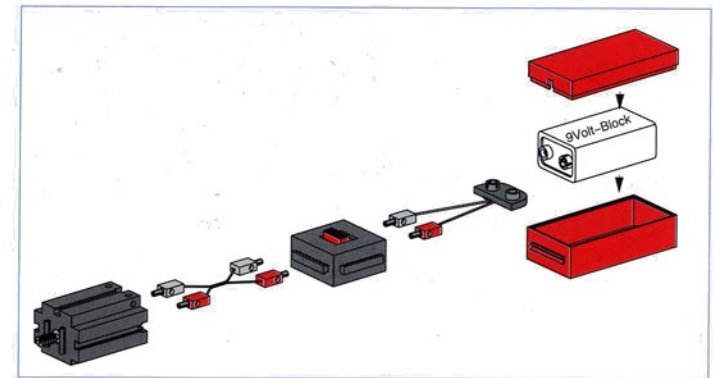
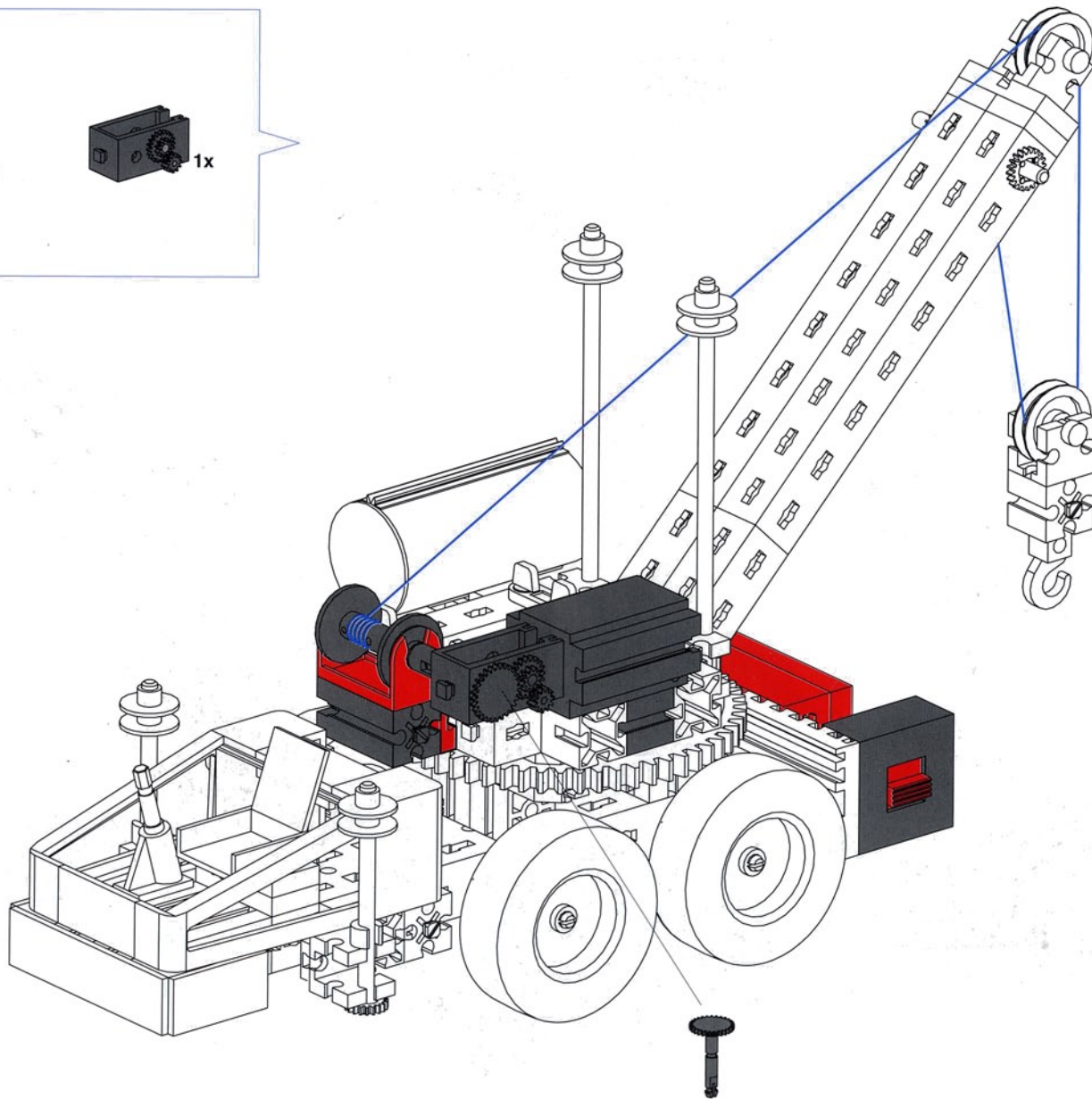
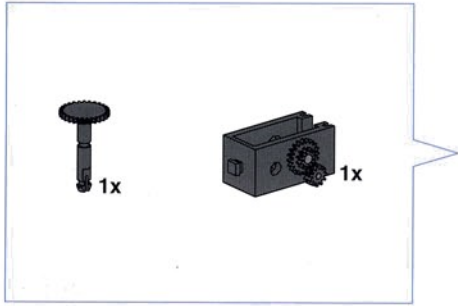

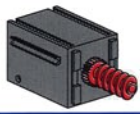

1

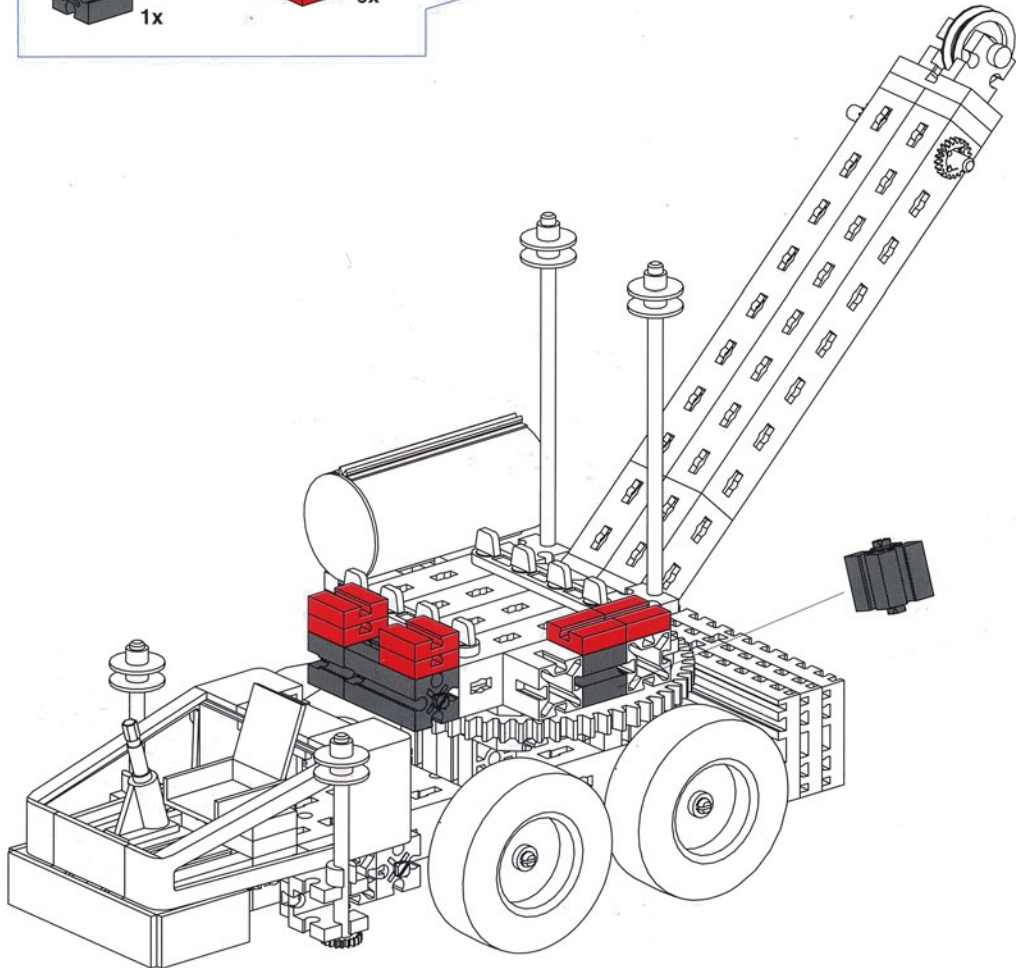
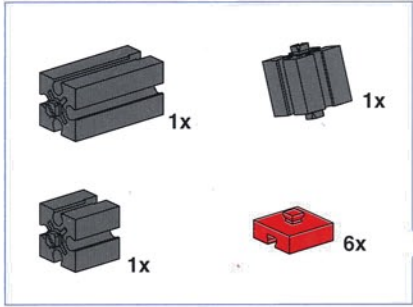

2

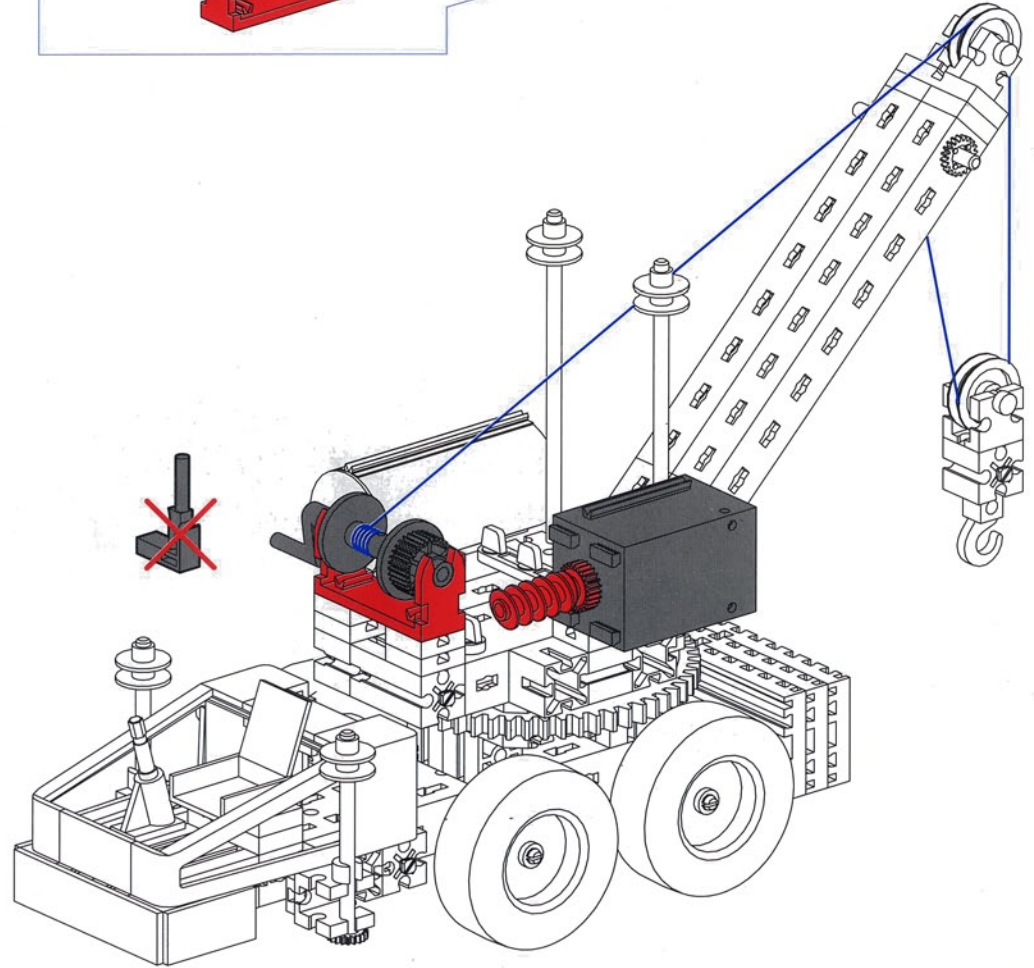
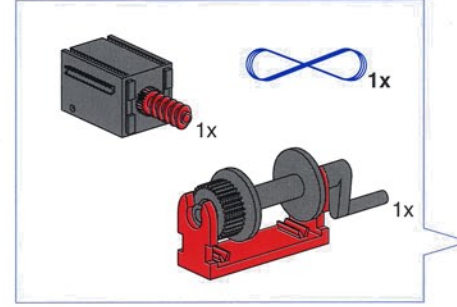

3

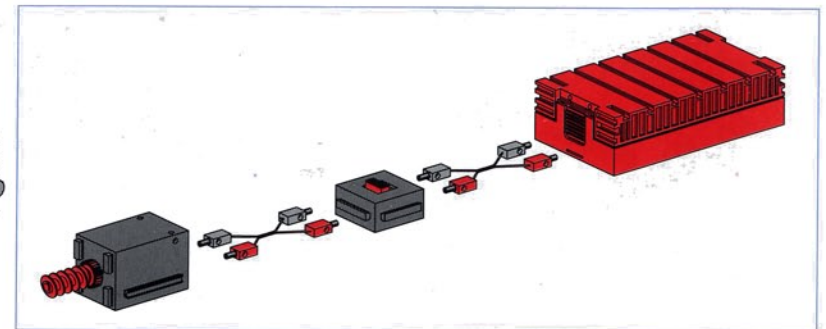
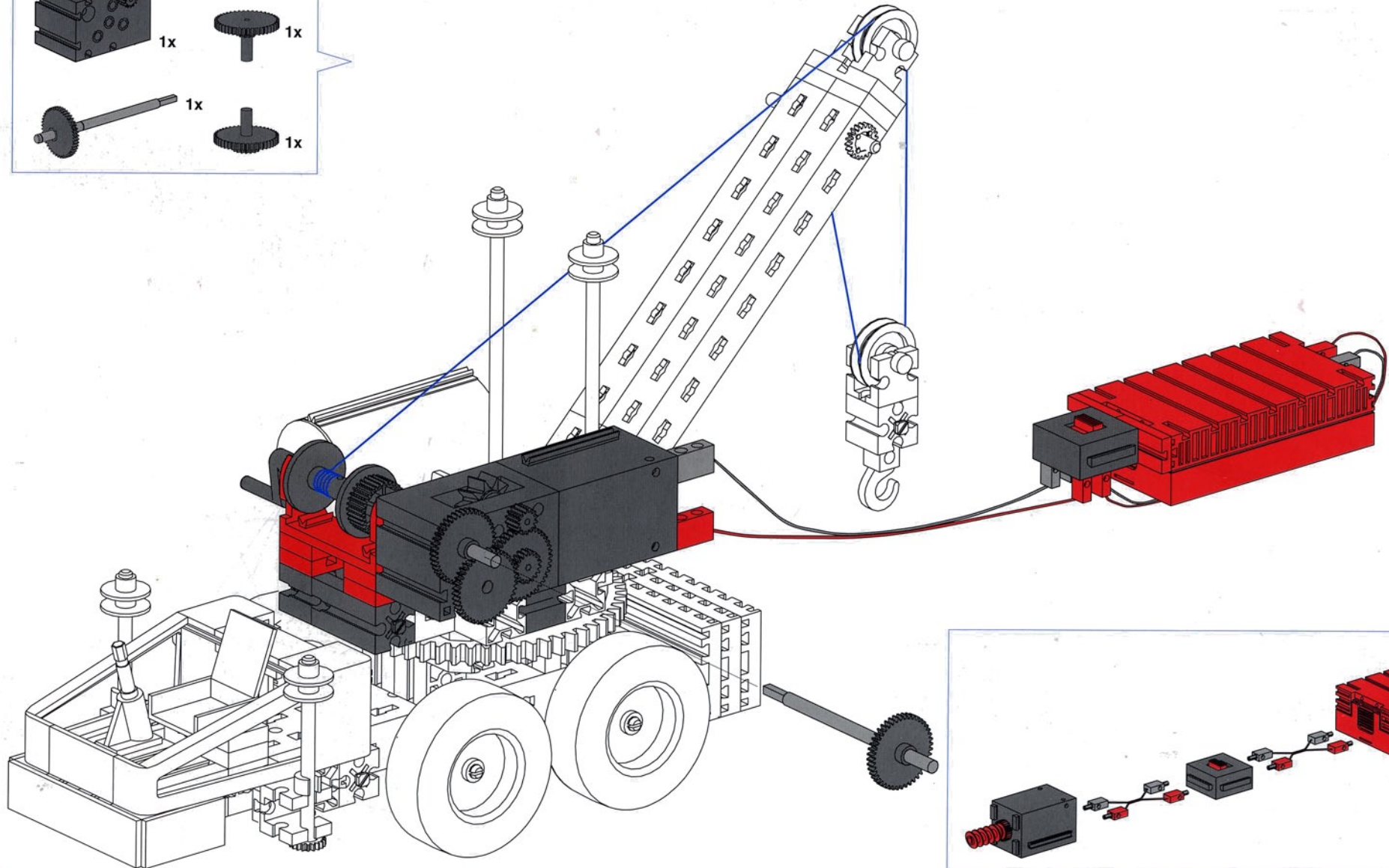
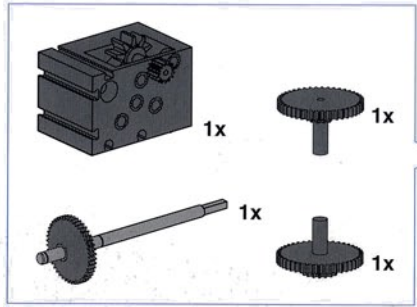

Radio Service

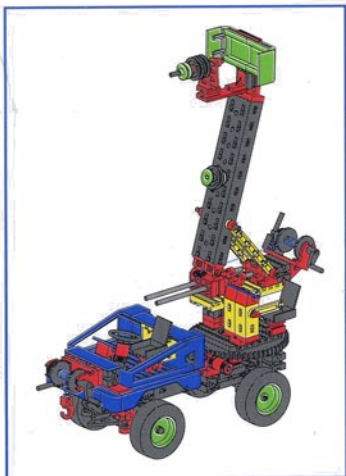

1

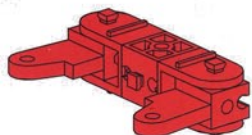
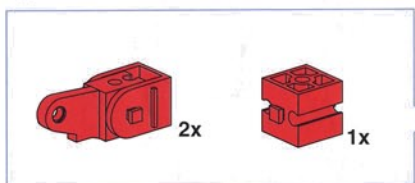

2

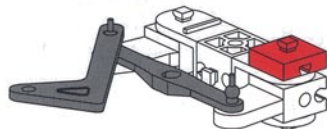
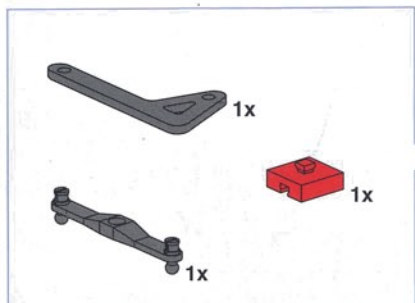

3

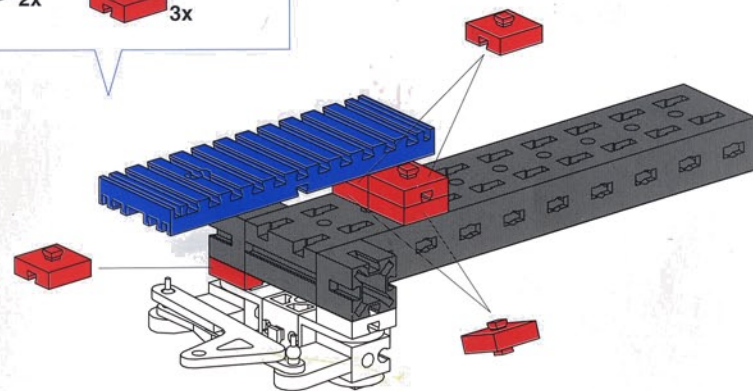
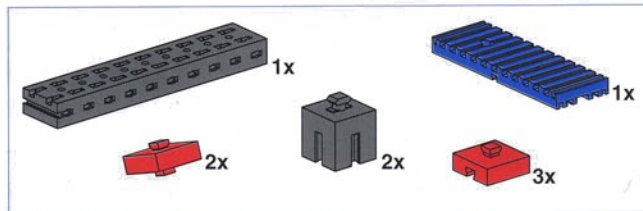

4

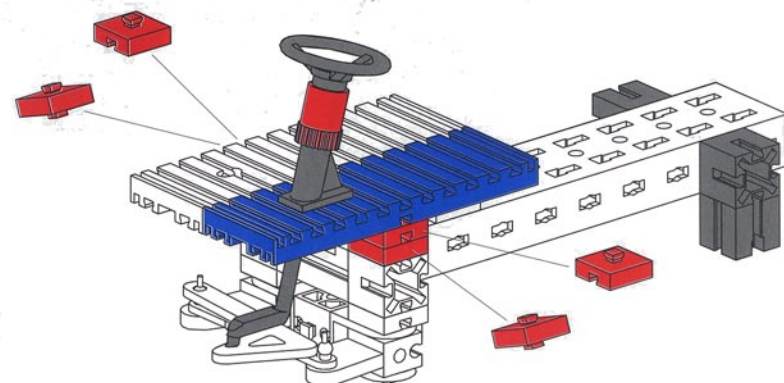
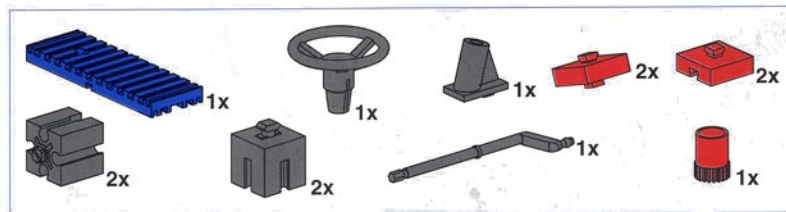

5

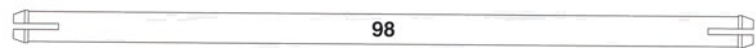
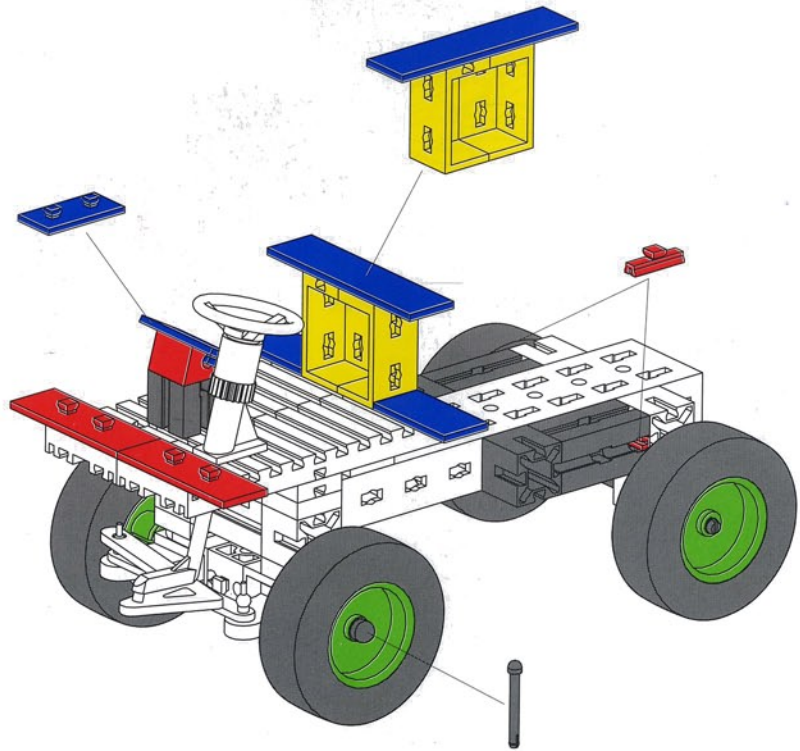
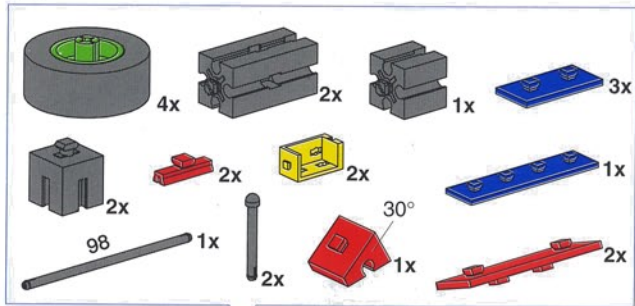

6

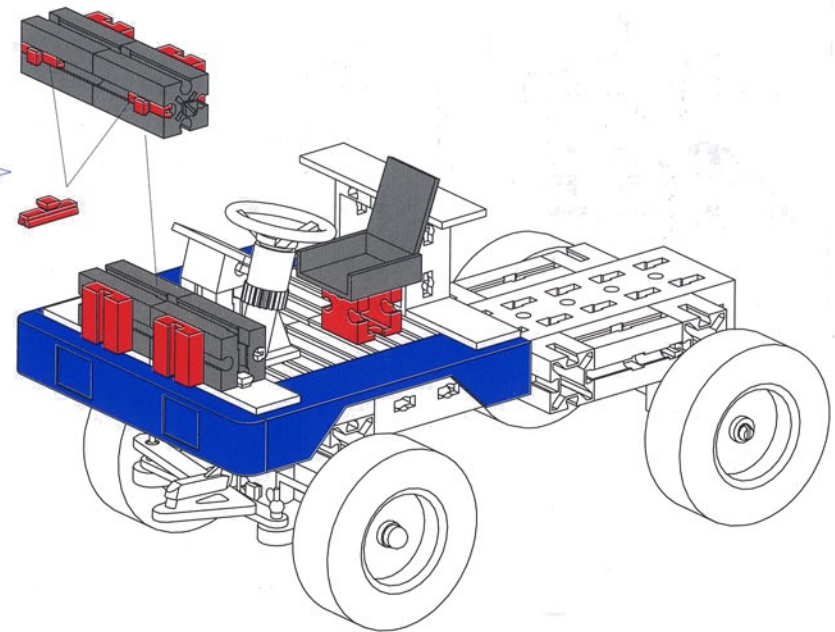
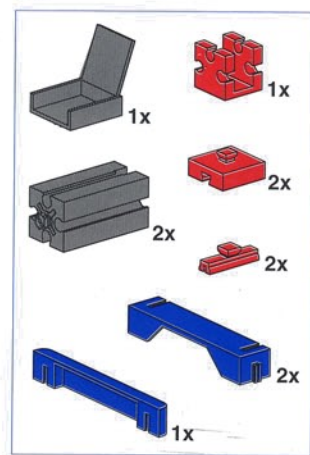

7

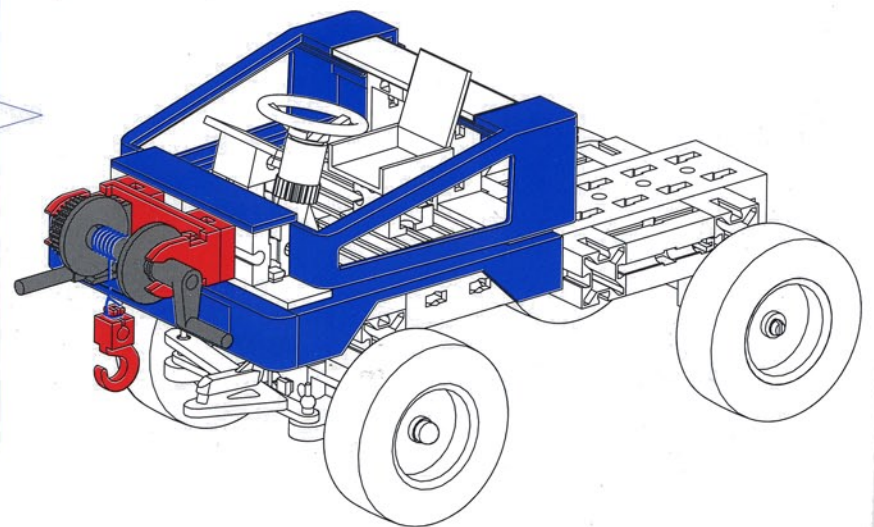
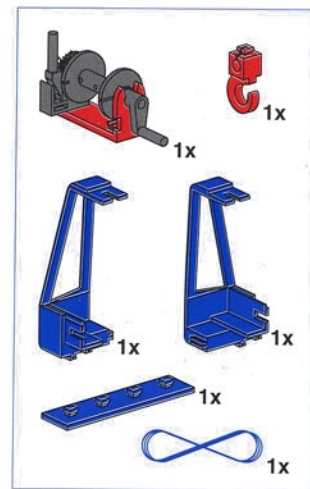

8

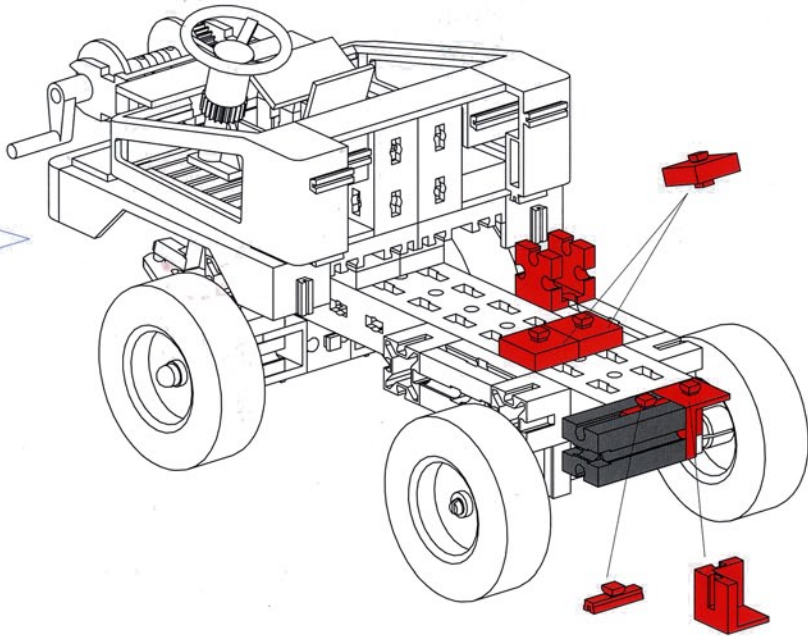
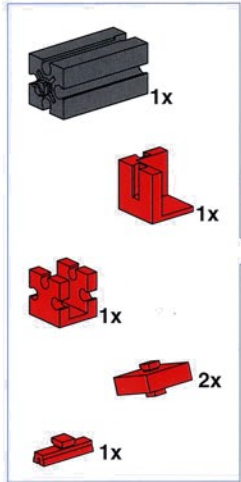

9

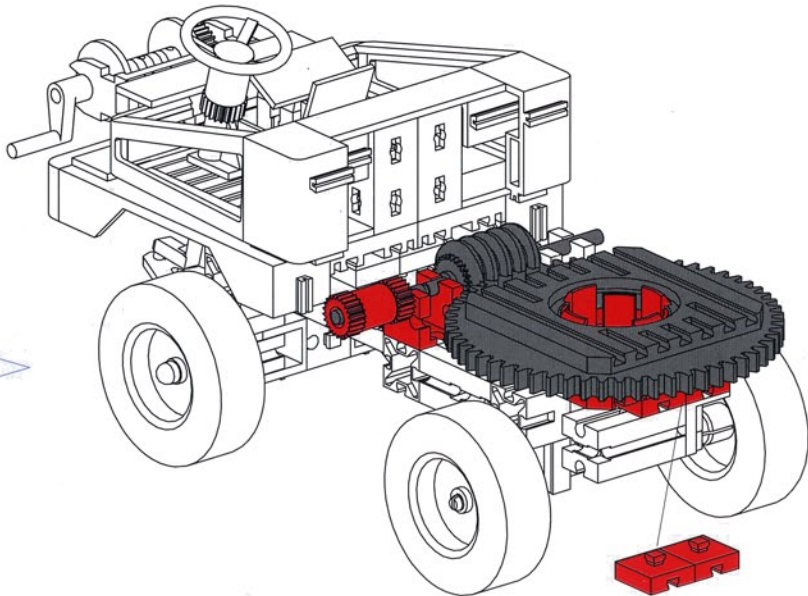
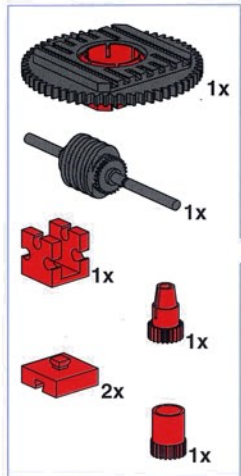

10

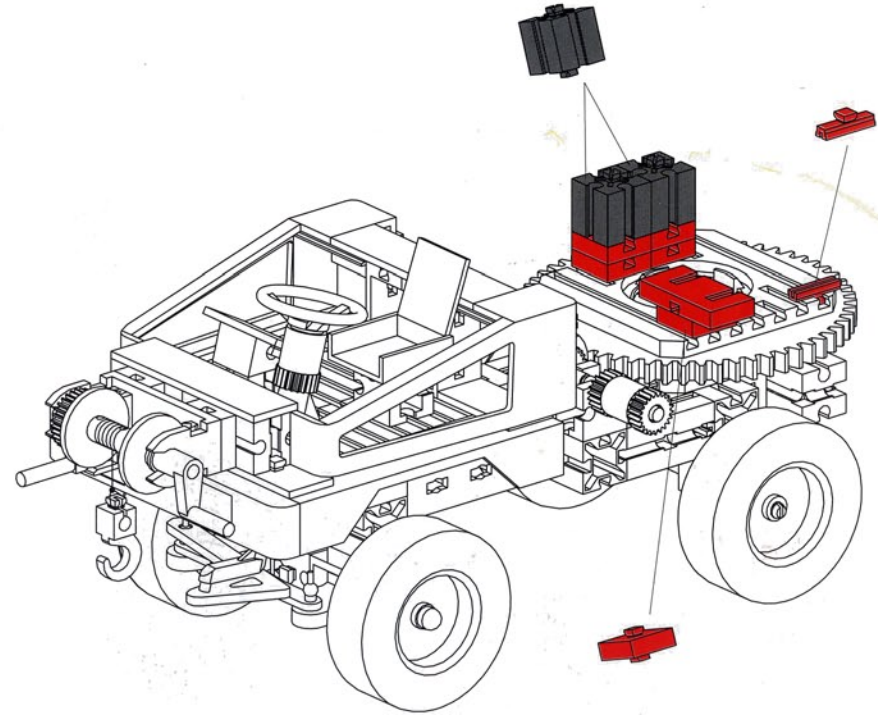
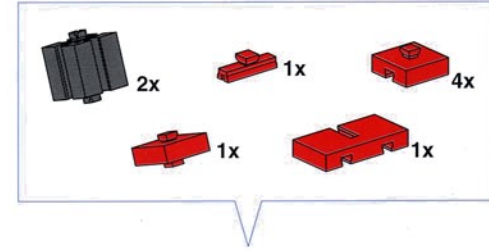

11

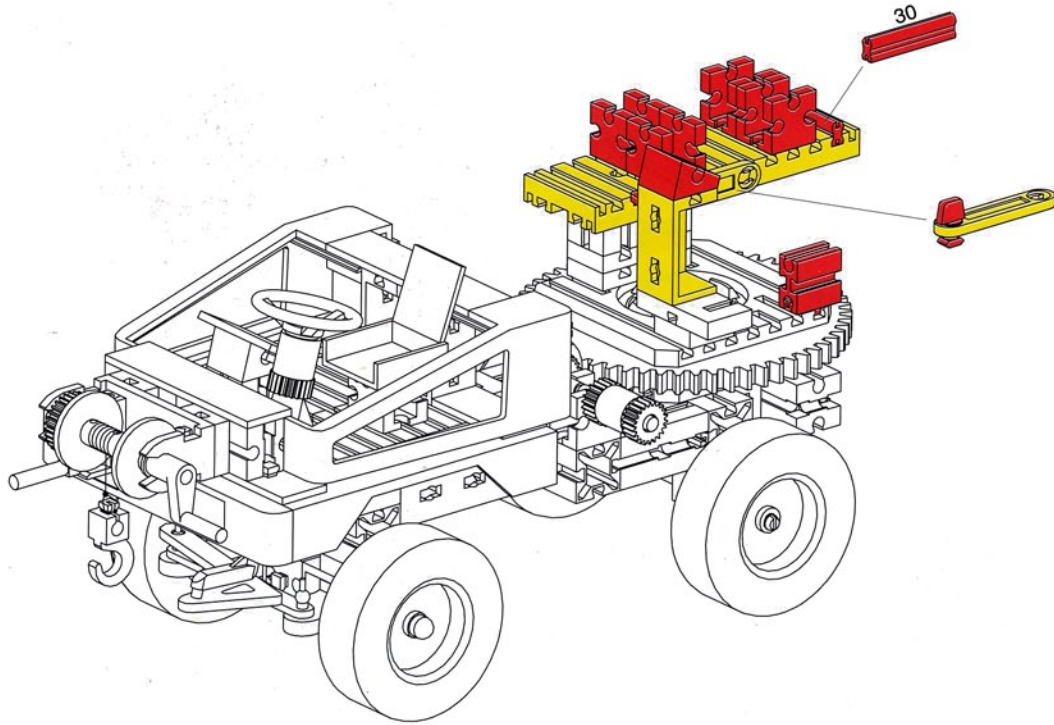
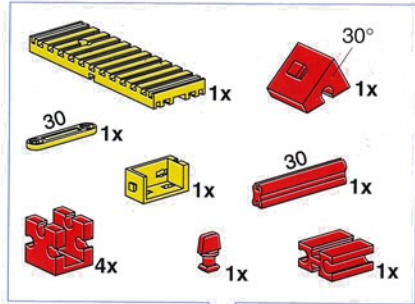

12

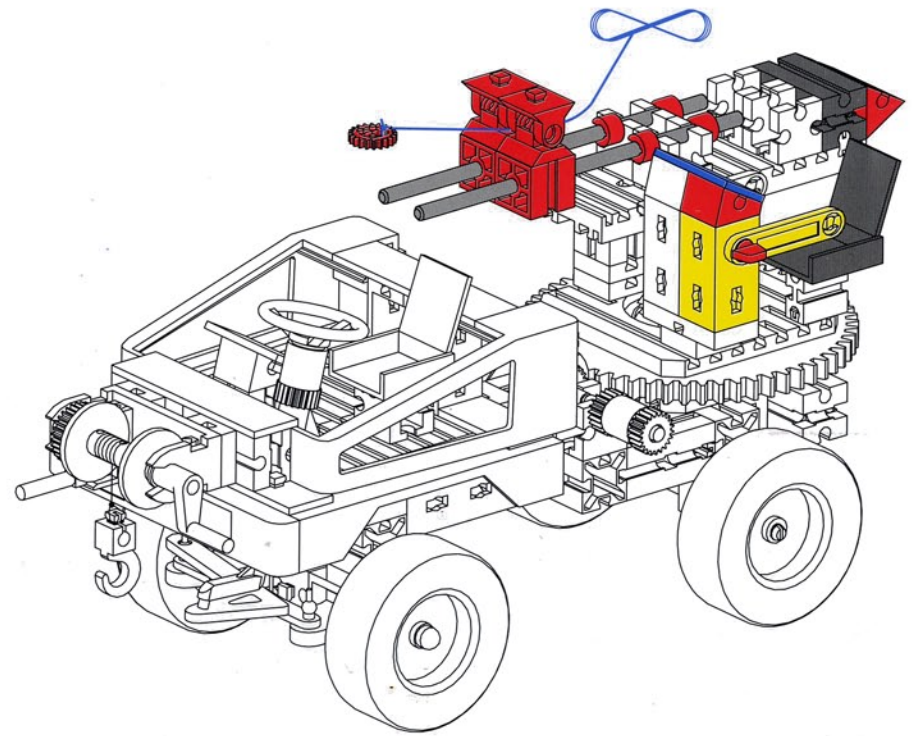
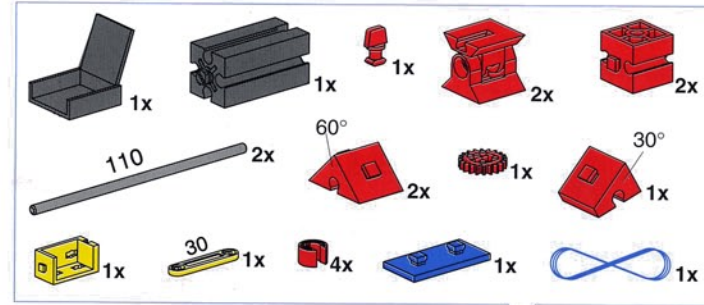

13

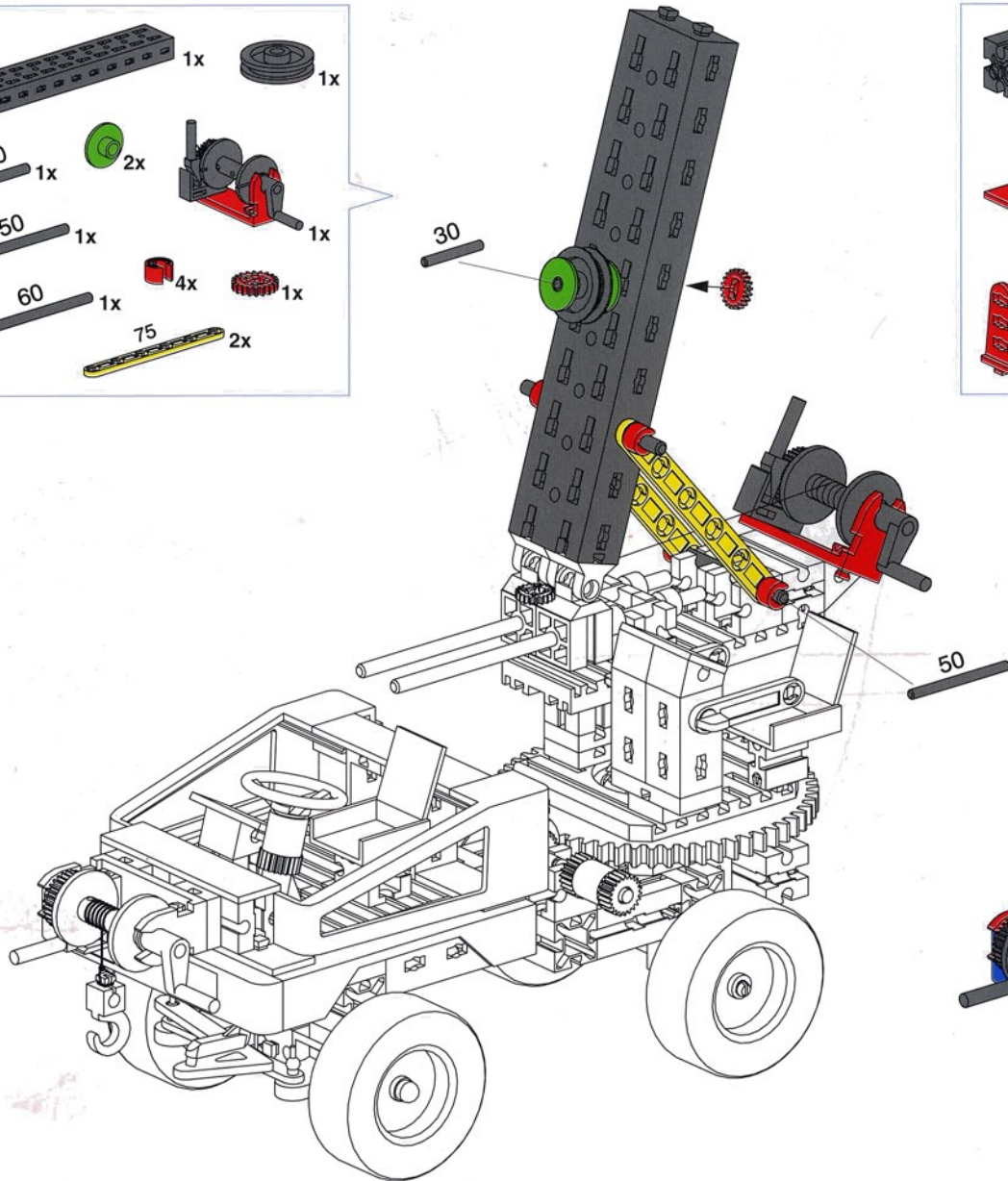
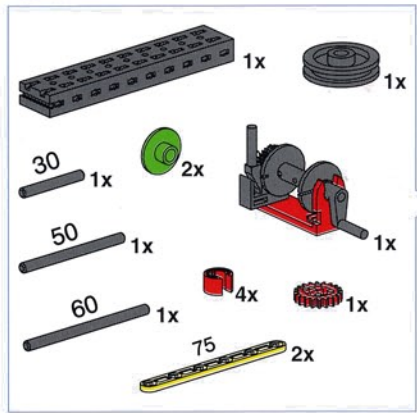

14

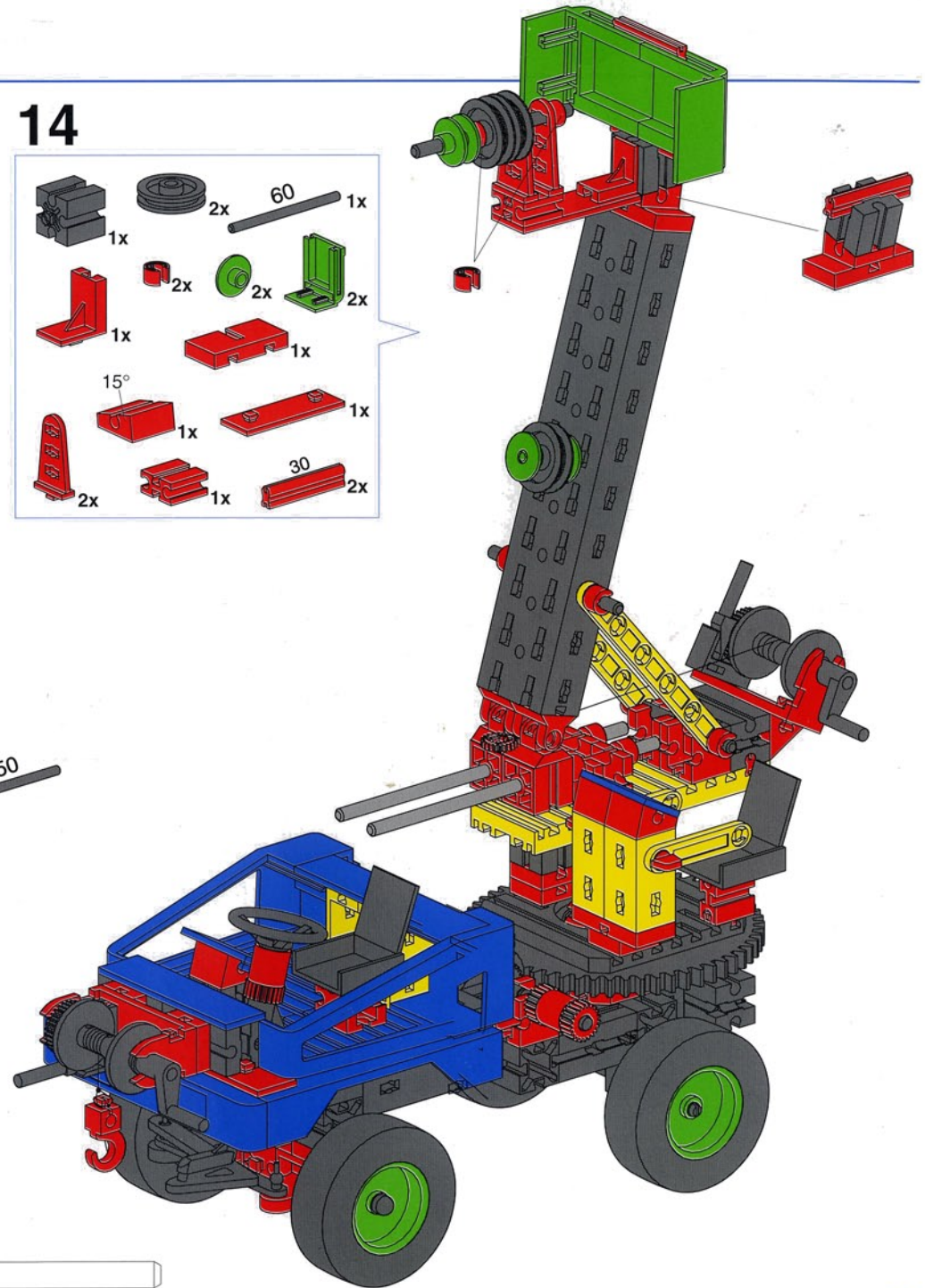
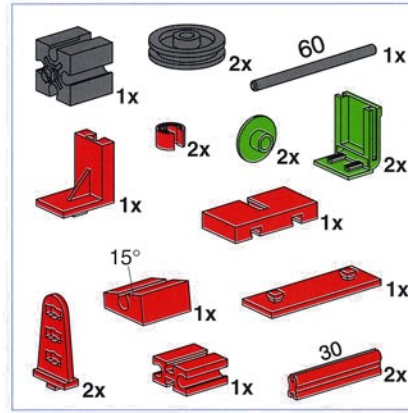







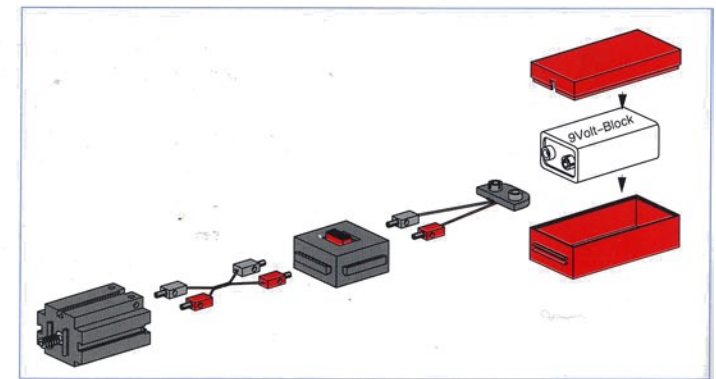
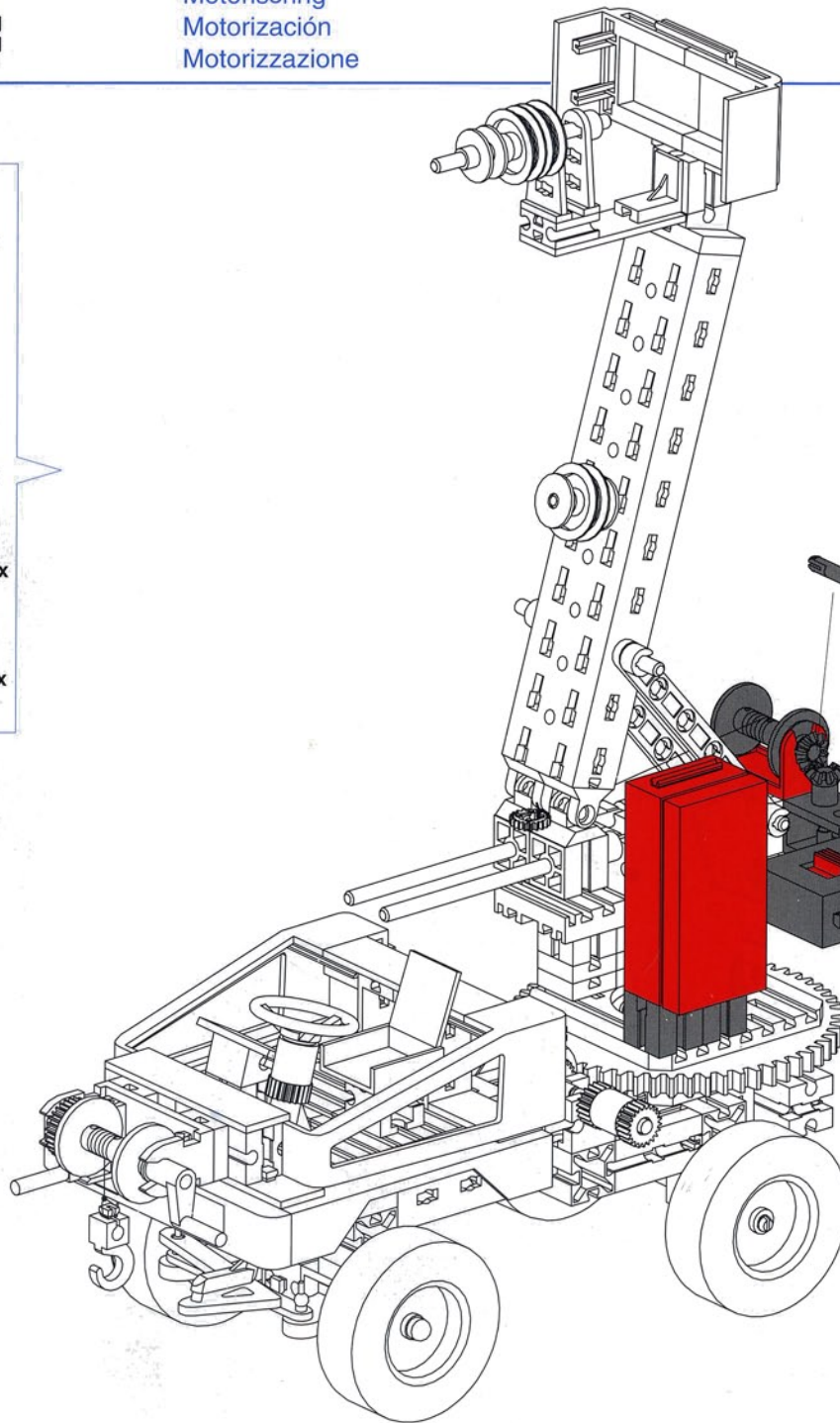
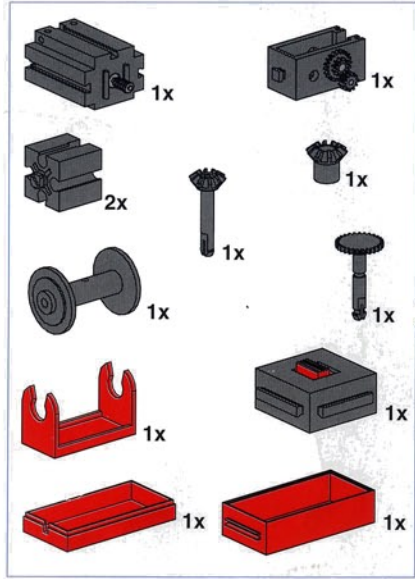

30

50

60



	1x		2x
	1x		2x
	1x		2x
	4x		1x

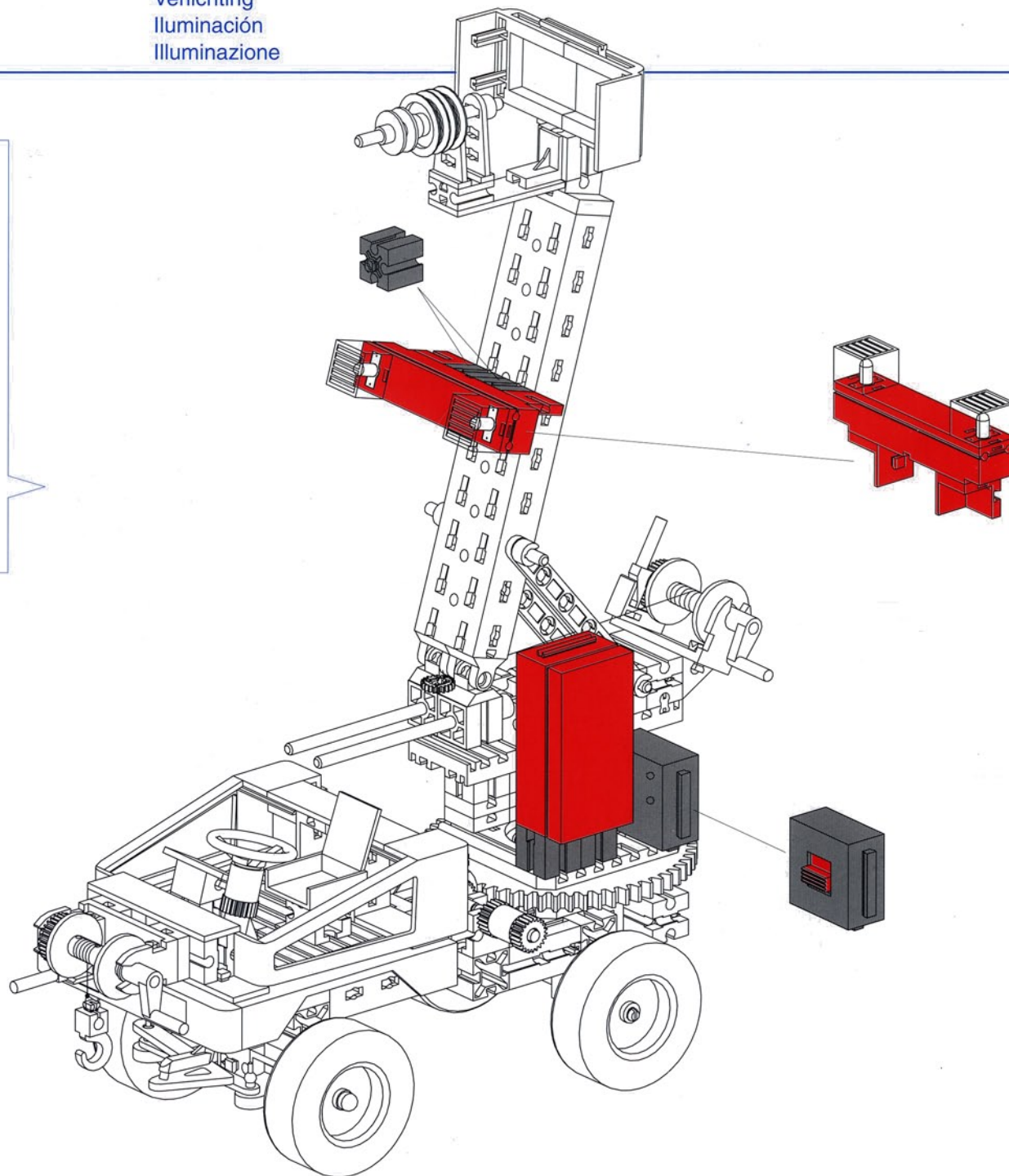



1-9 Seite 32-34
Page 32-34
Page 32-34
Página 32-34
Página 32-34
Página 32-34

10

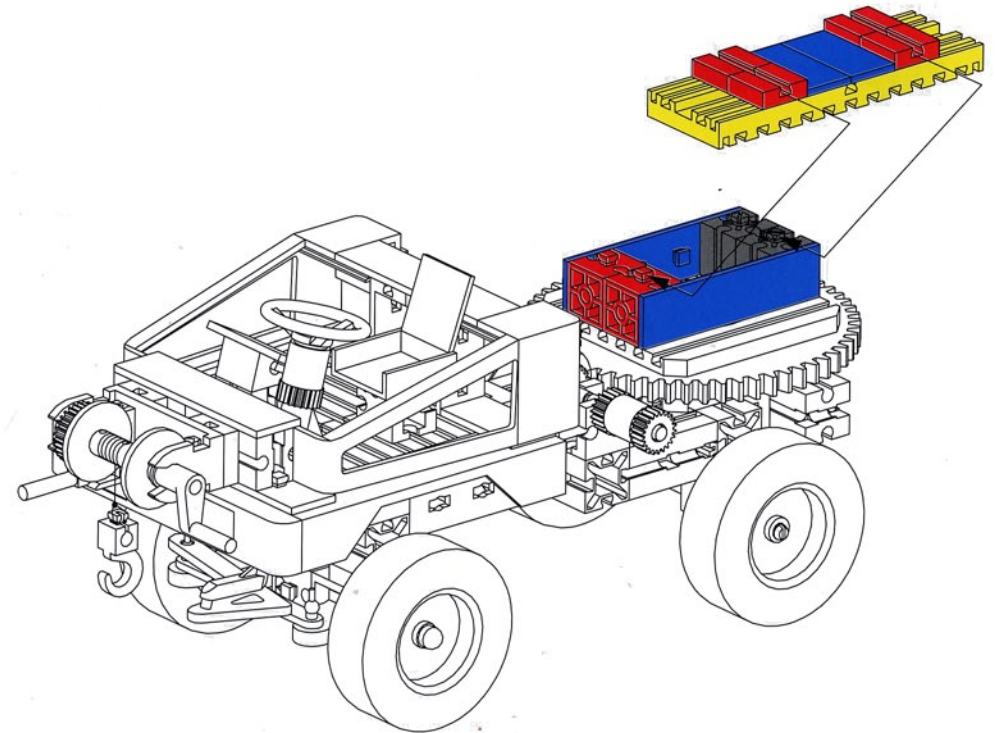
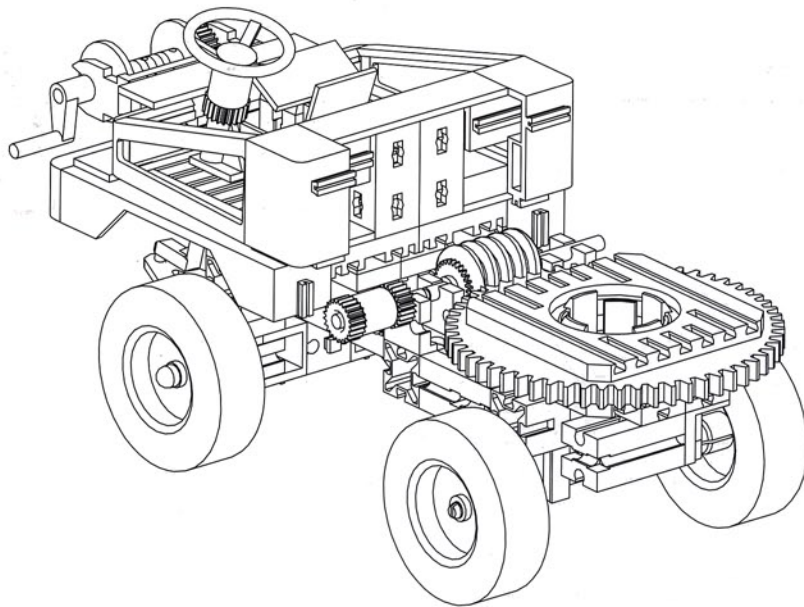
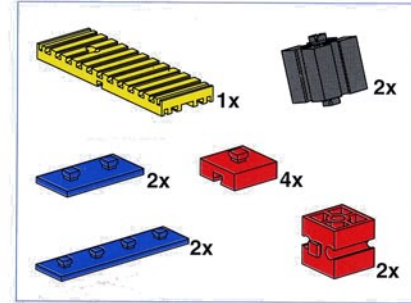

11

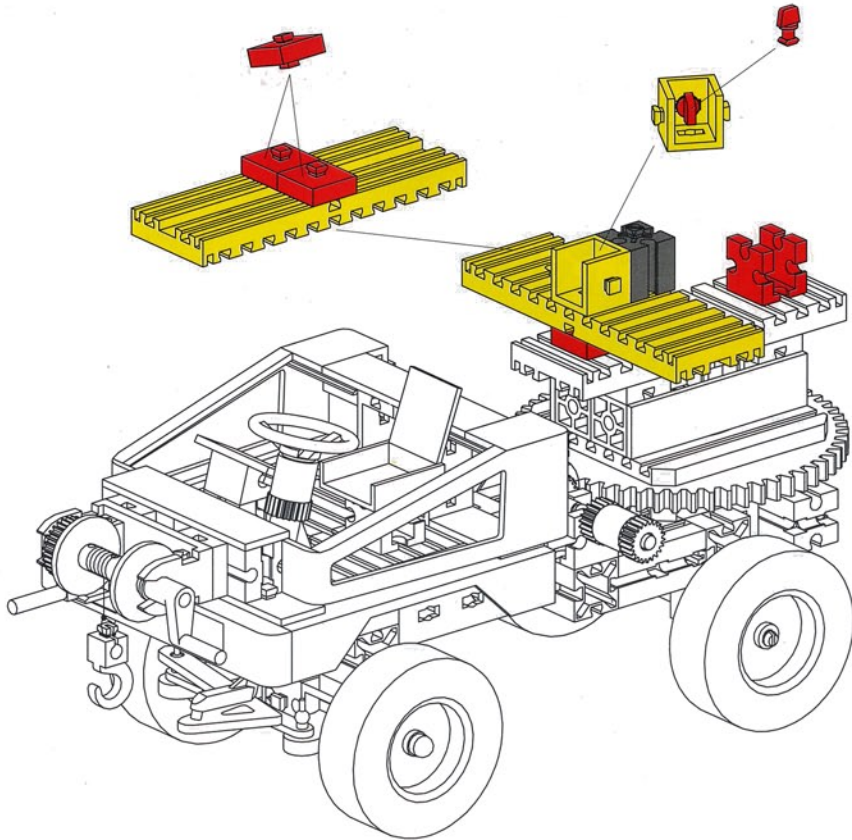
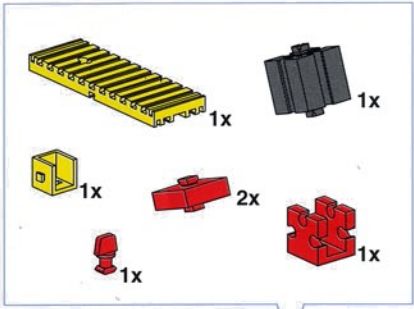

12

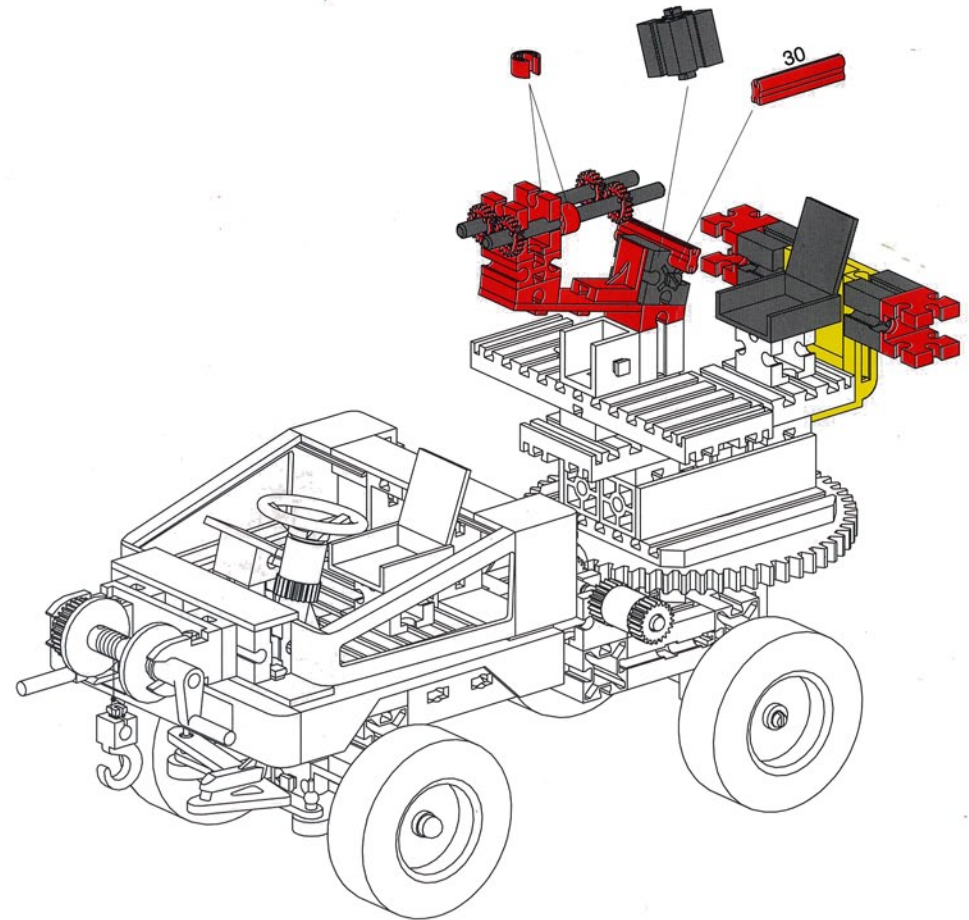
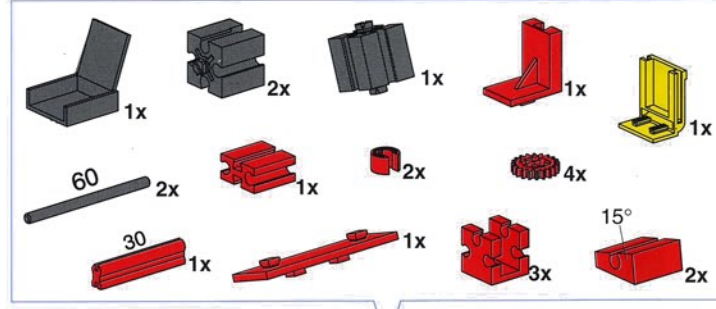

13

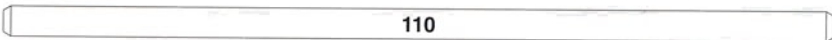
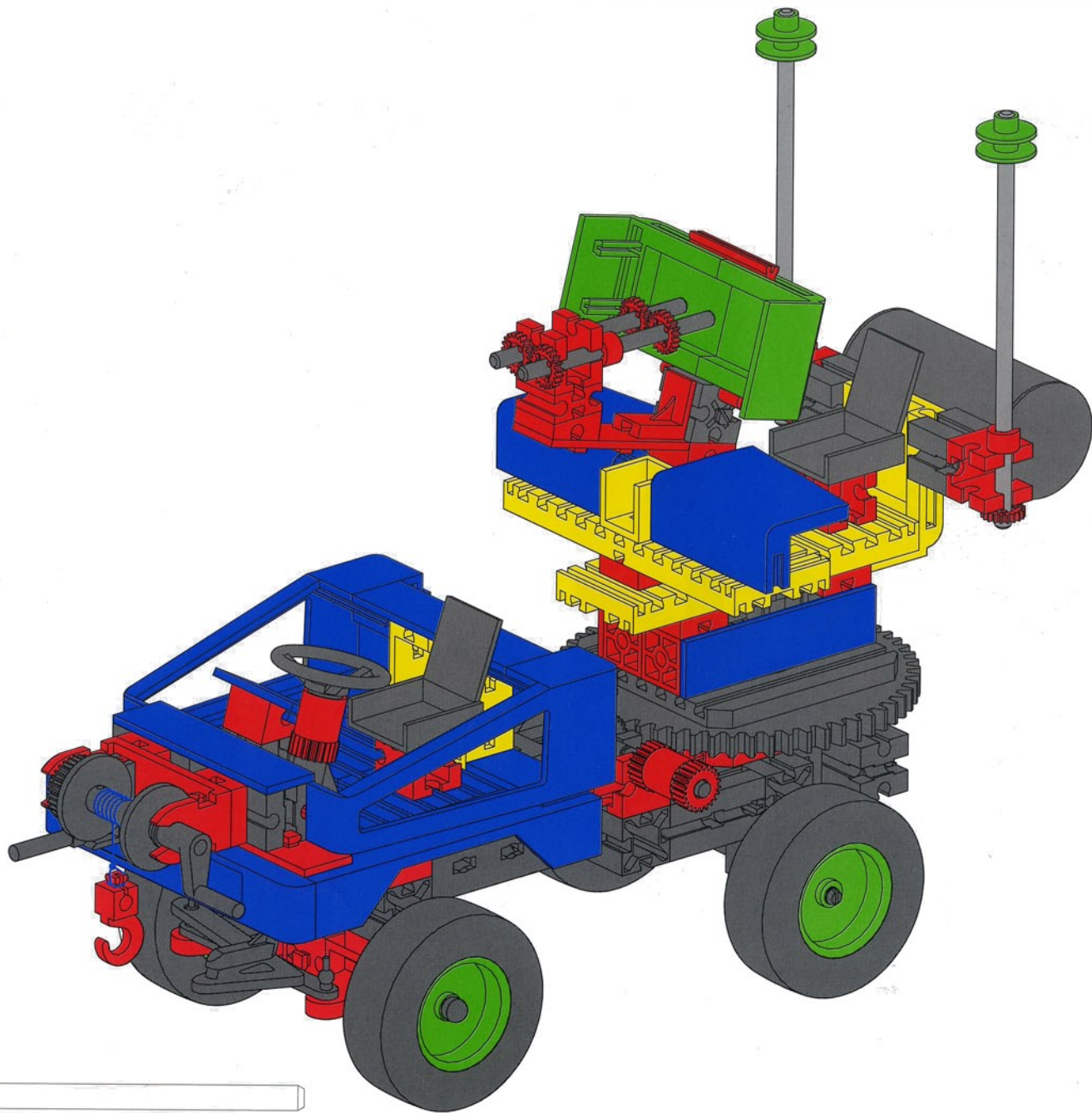
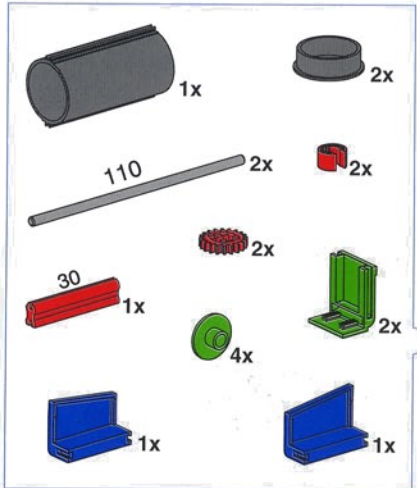

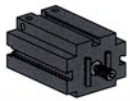

1

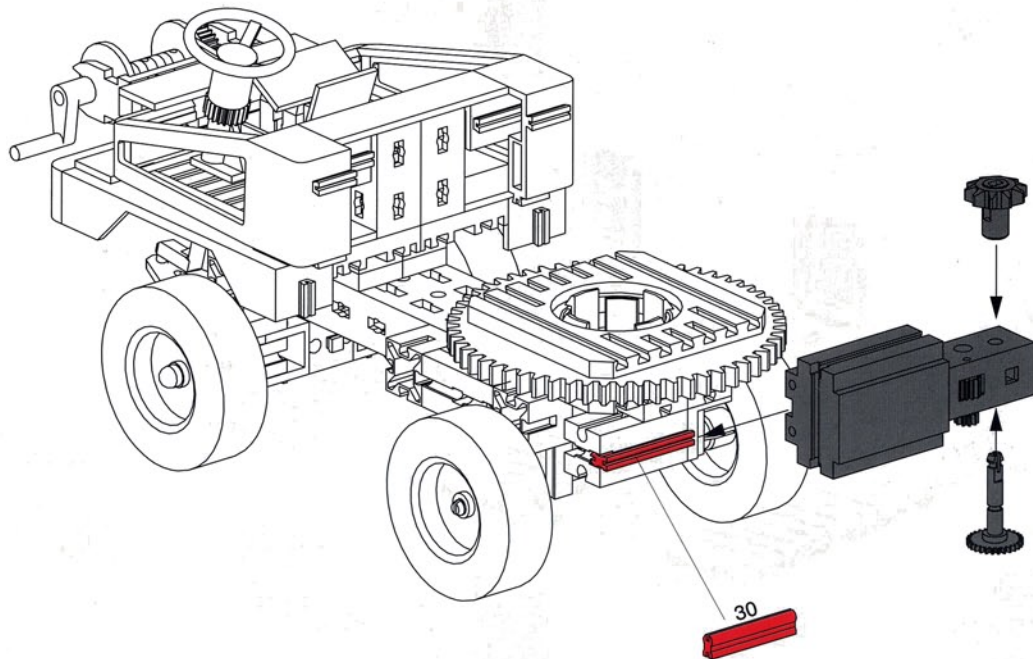
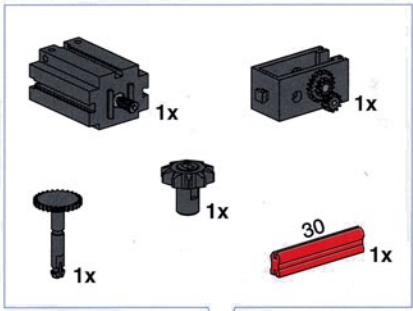

2

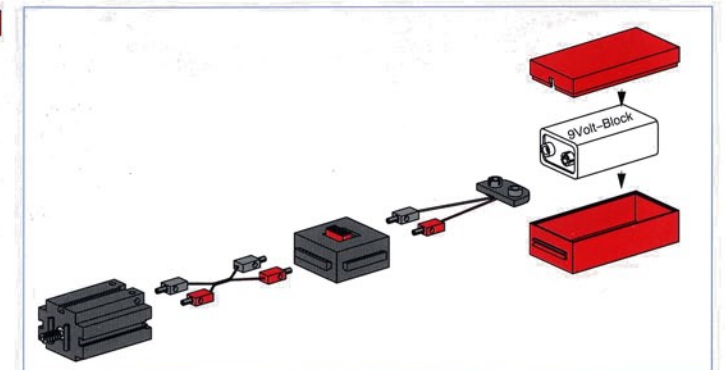
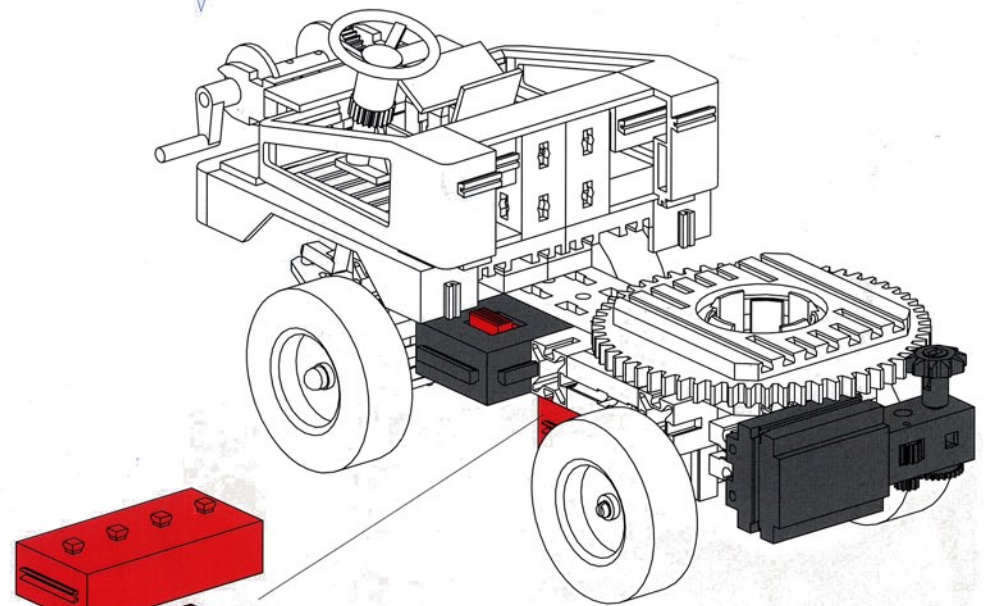
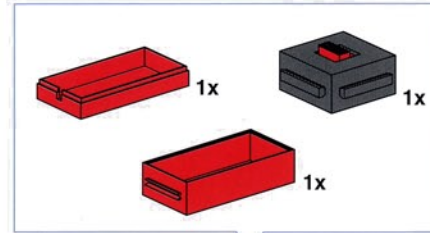

Pickup Truck

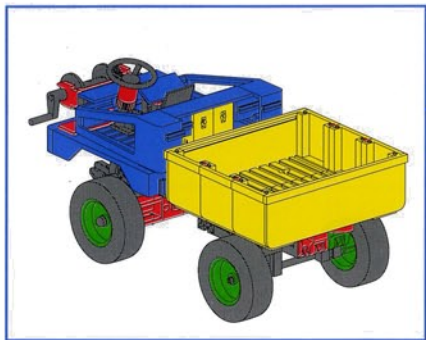

1-7 Seite 32-33
Page 32-33
Page 32-33
Página 32-33
Página 32-33

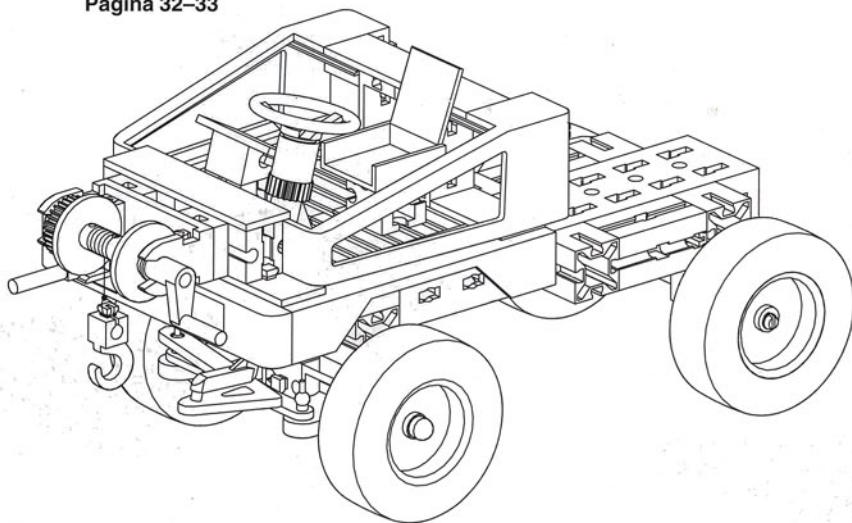

8

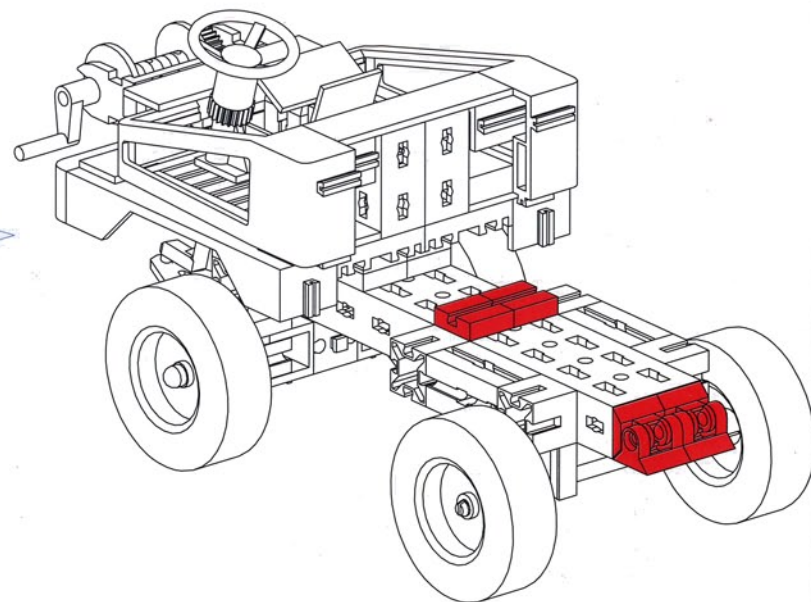
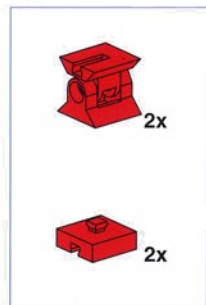

9

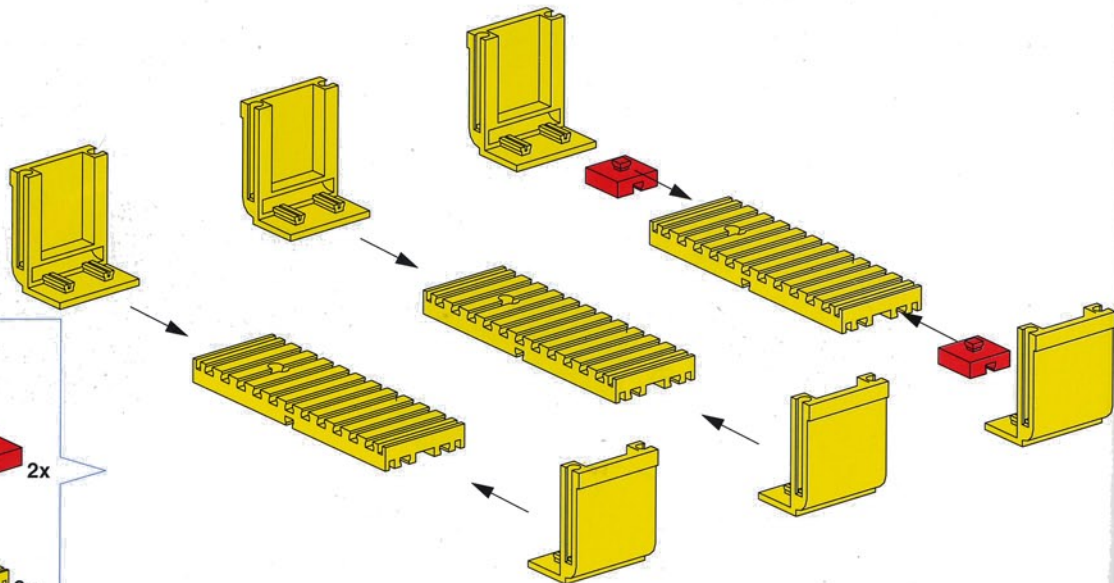
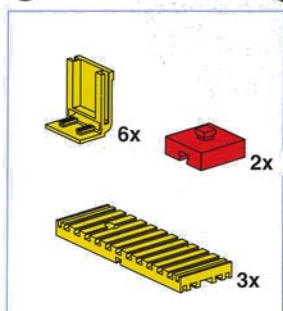

10

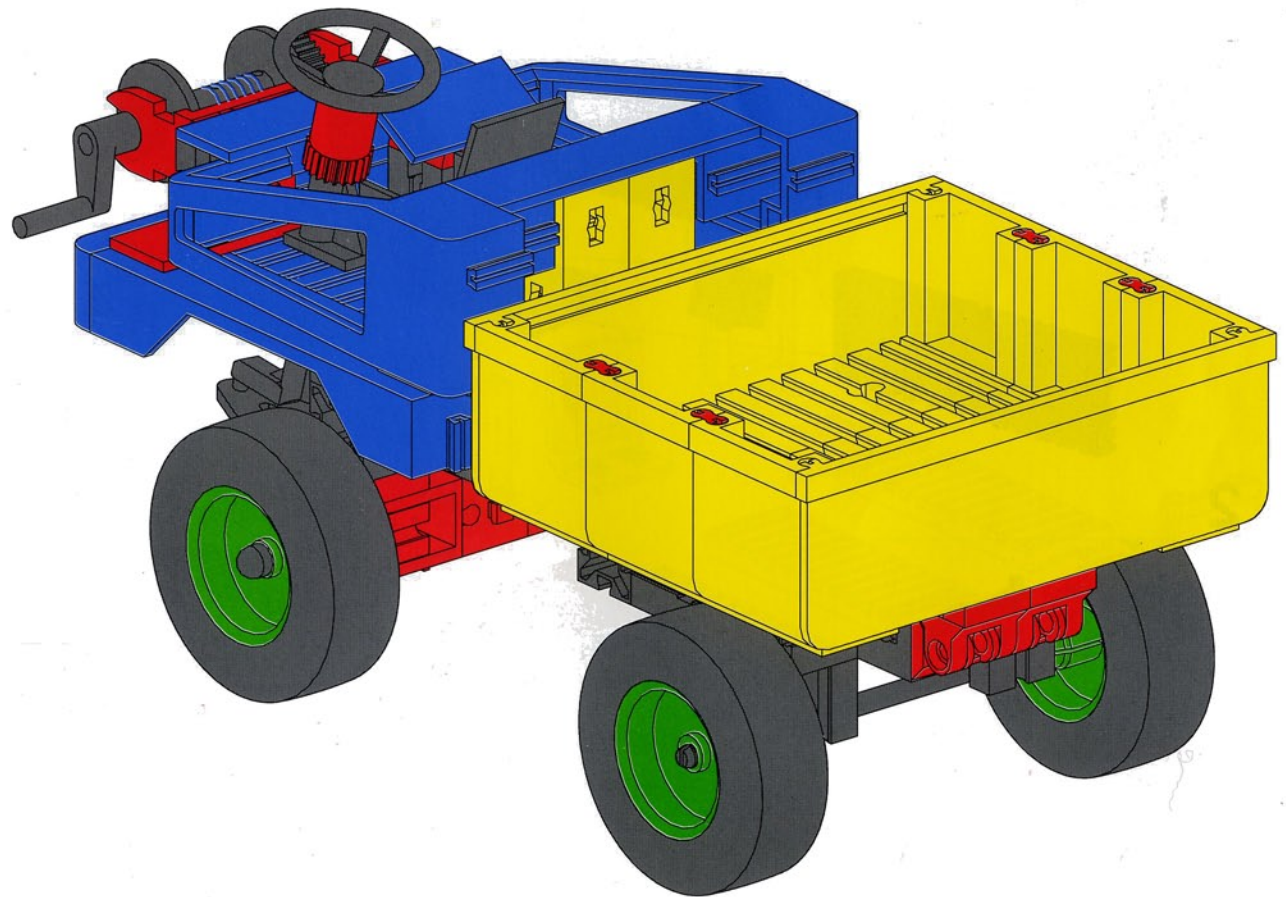
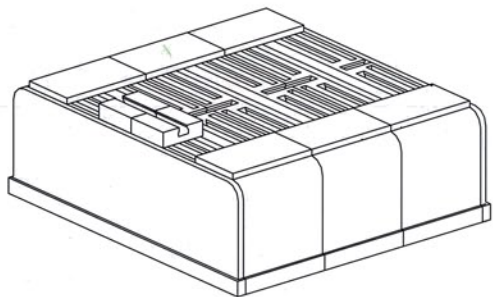
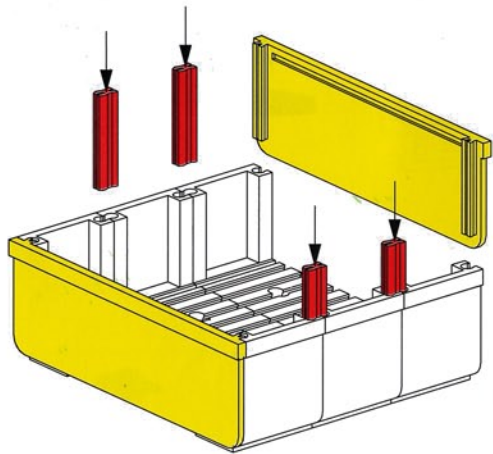
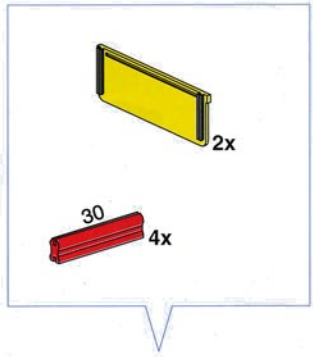

Motorisierung
Motor unit
Motorisation

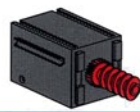

Motorisering
Motorización
Motorizzazione

Motor-Set
30310

oder - or - ou
of - o - oppure

Motor Master
30302



1

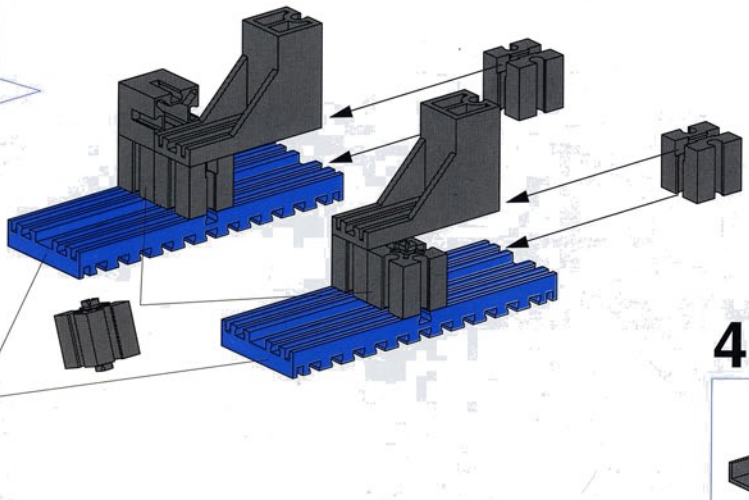
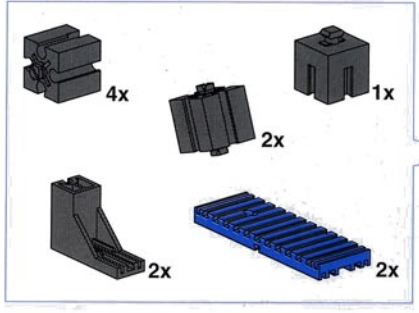

2

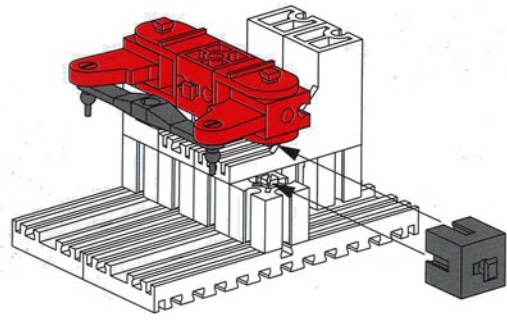
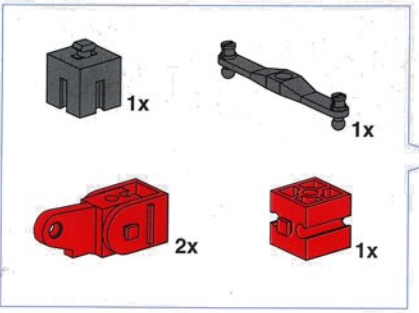

3

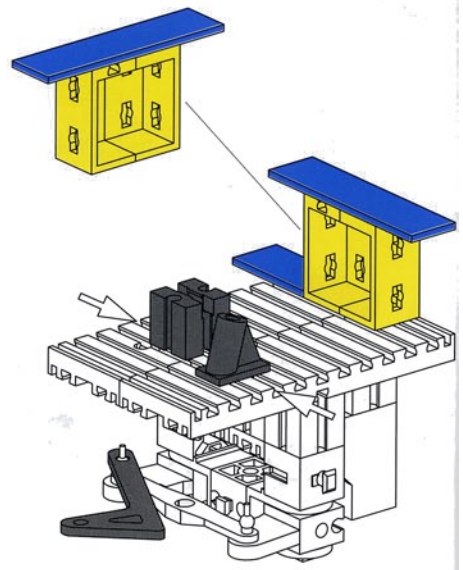
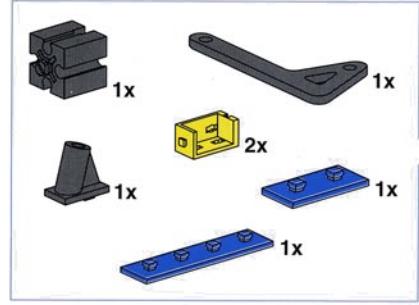

4

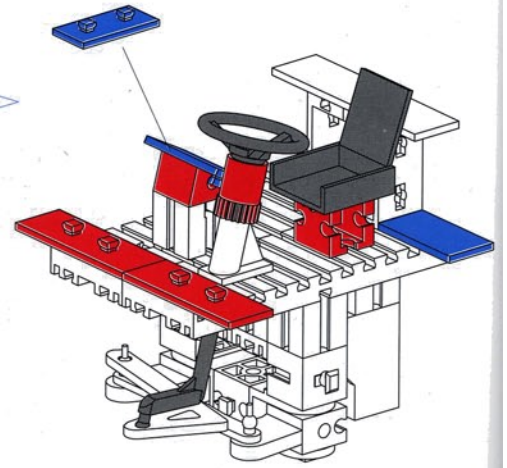
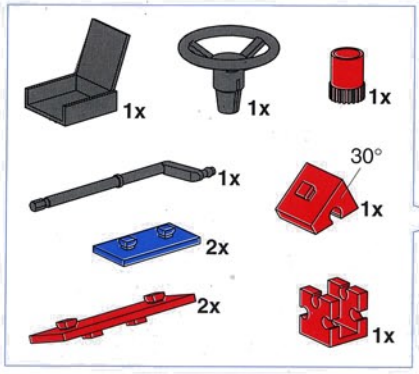

5

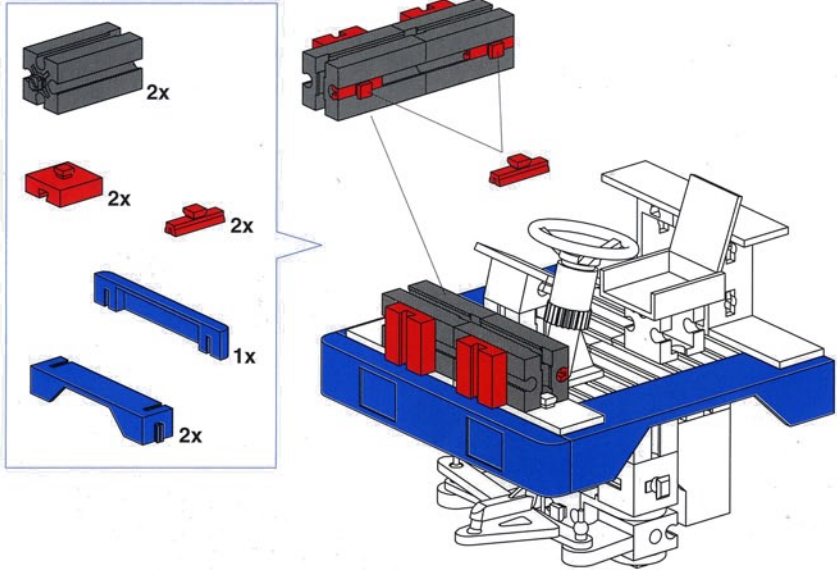

7

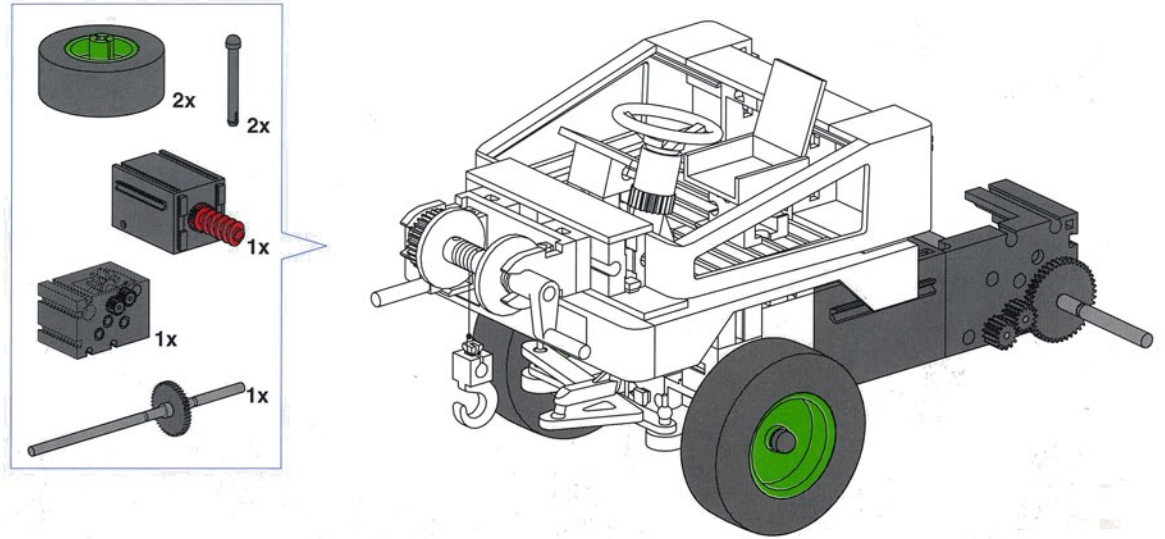

6

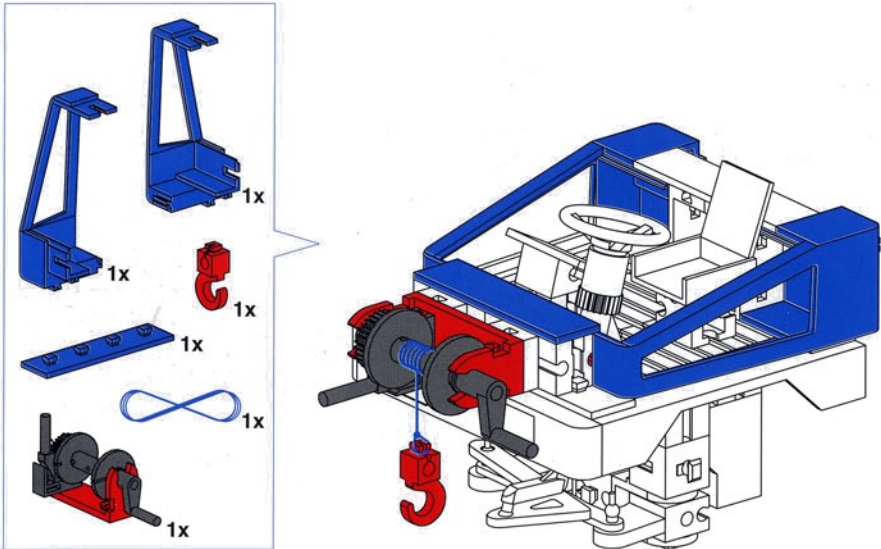

8

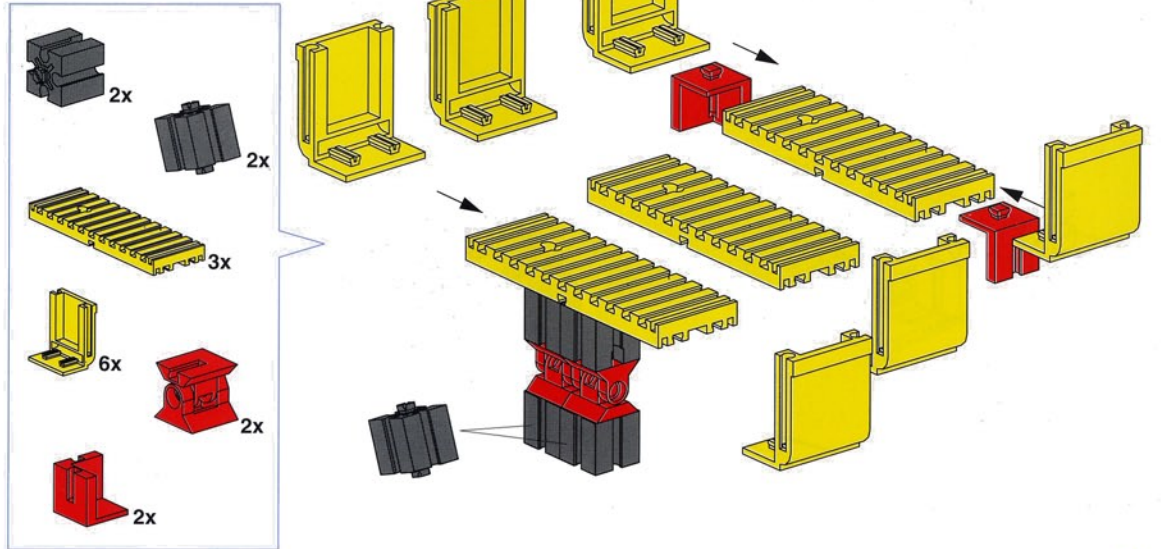

9

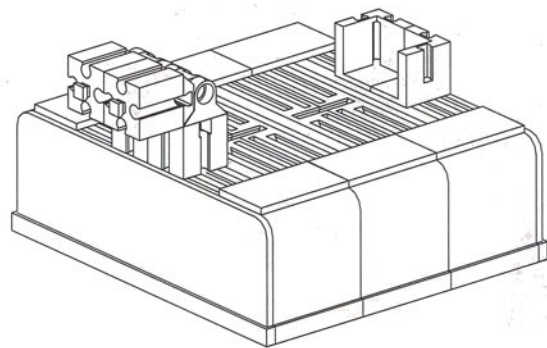
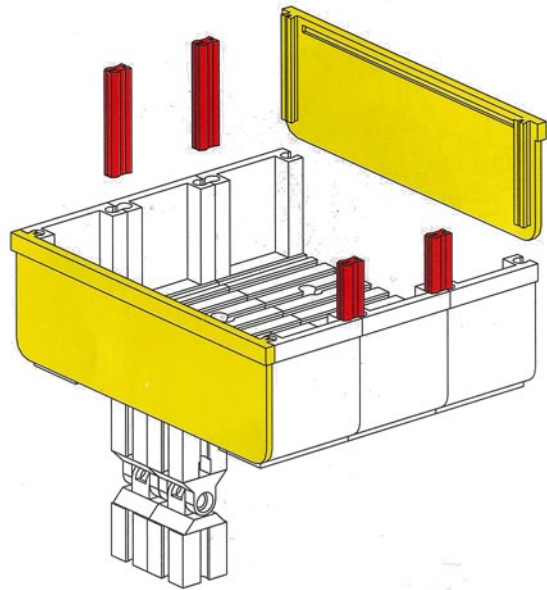
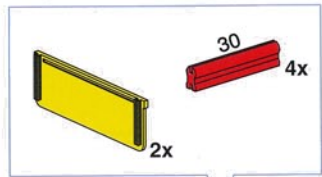

10

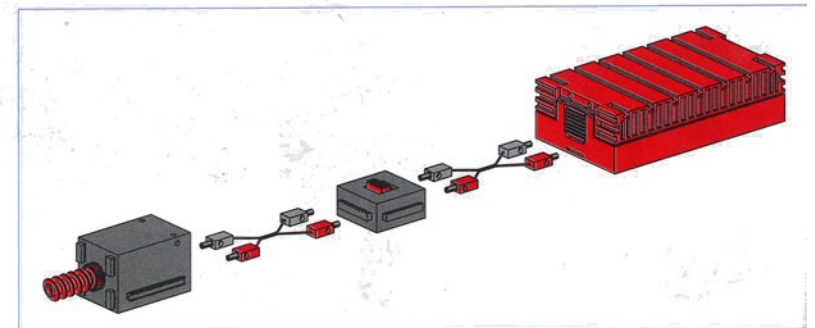
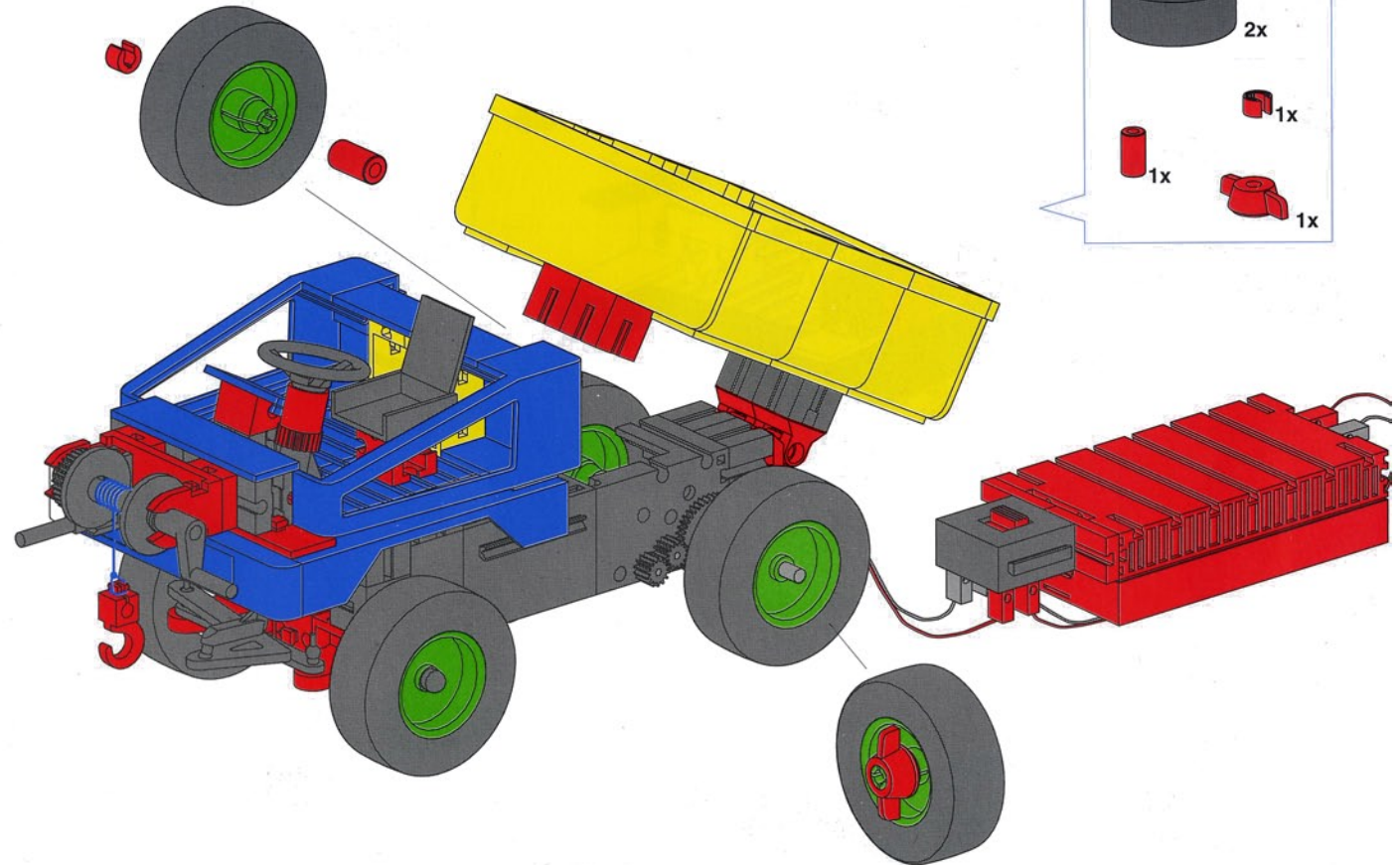
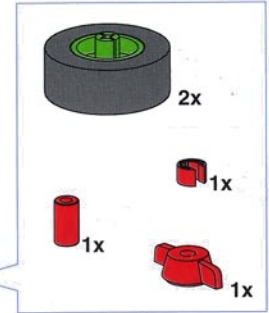

X-Wing Glider

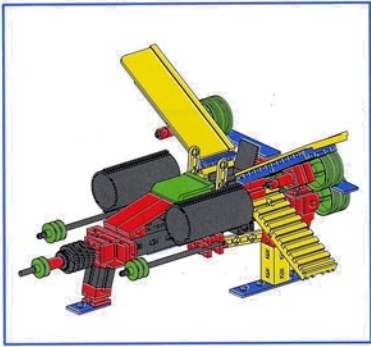

1

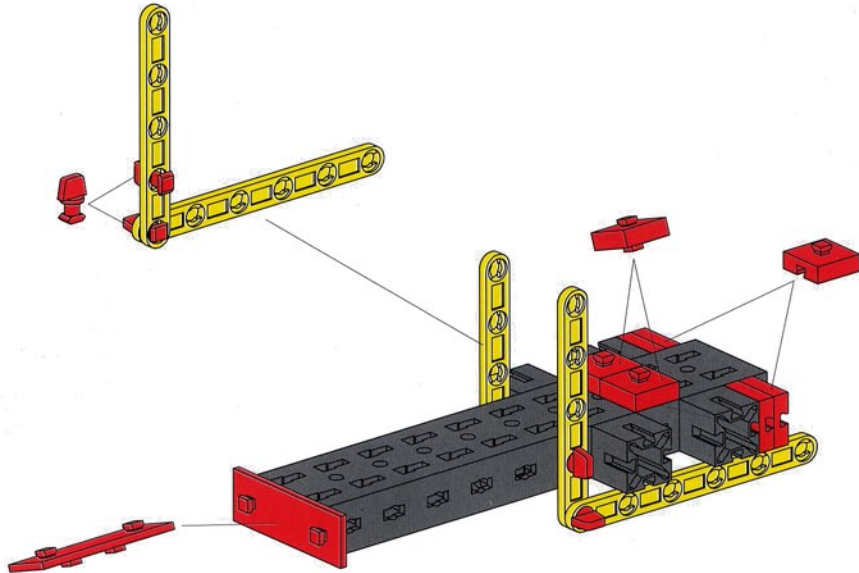
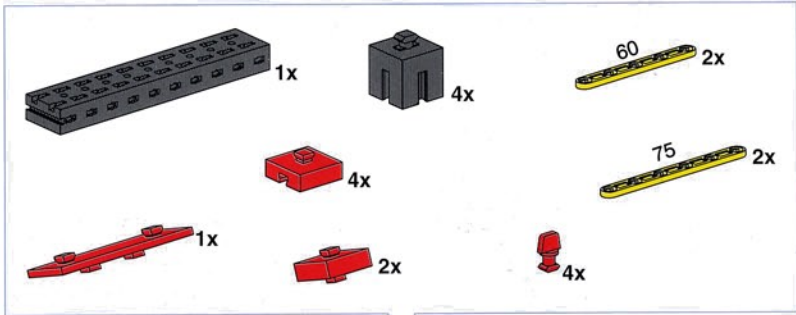

2

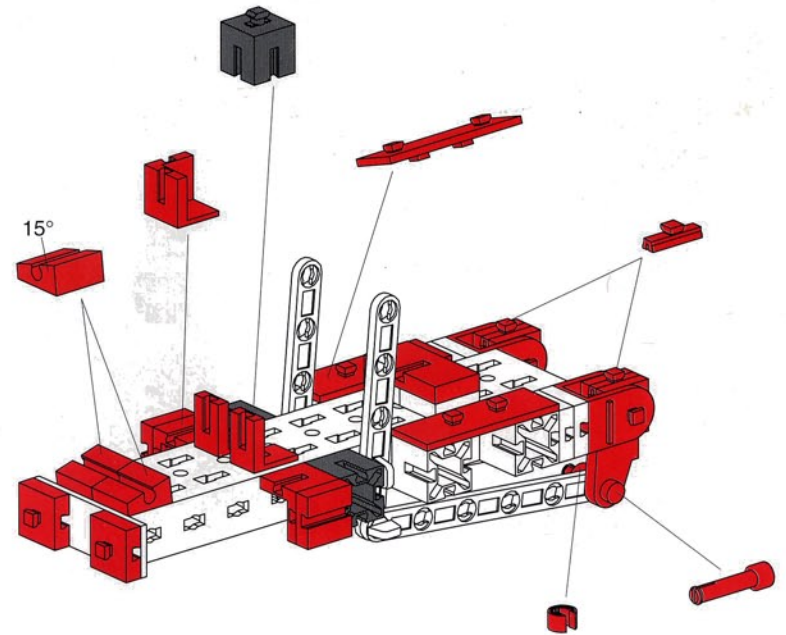
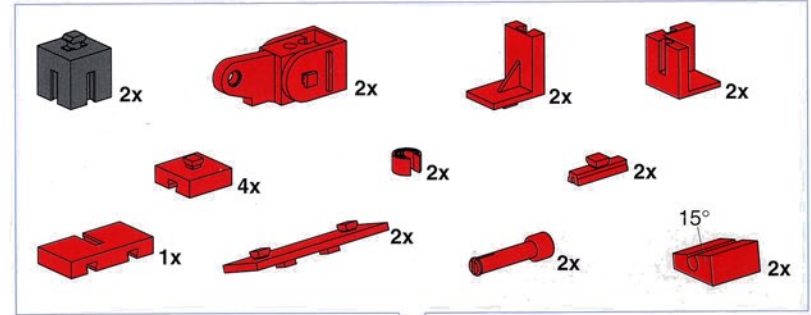

3

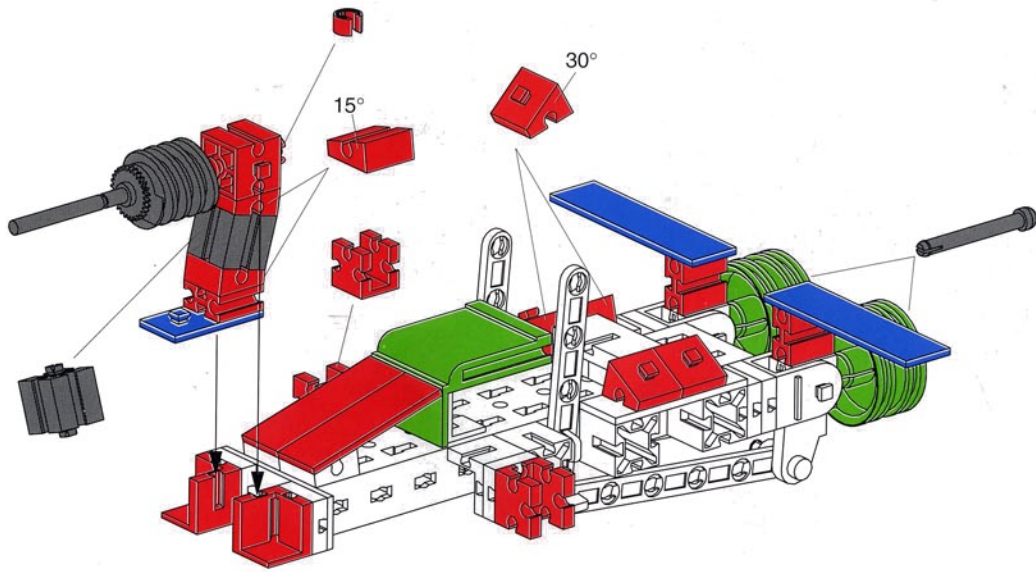
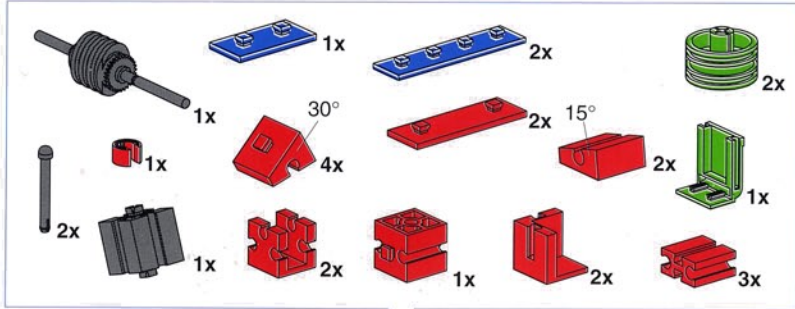

4

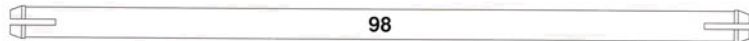
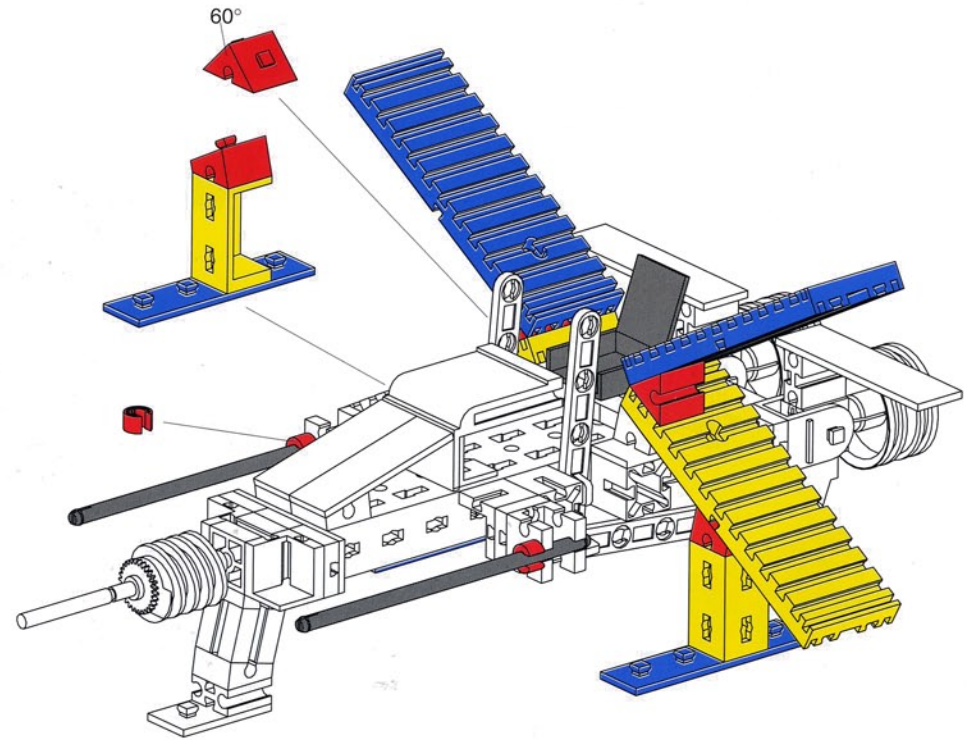
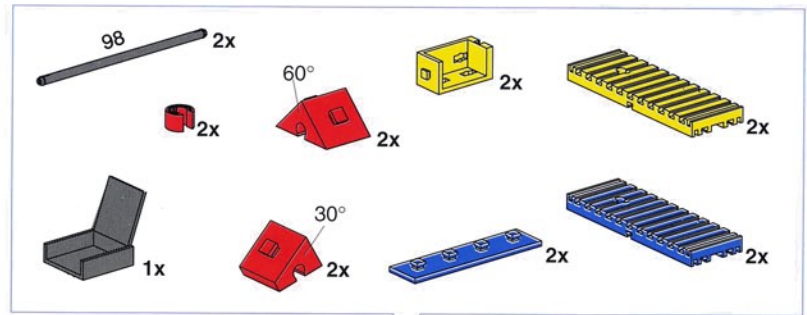

5

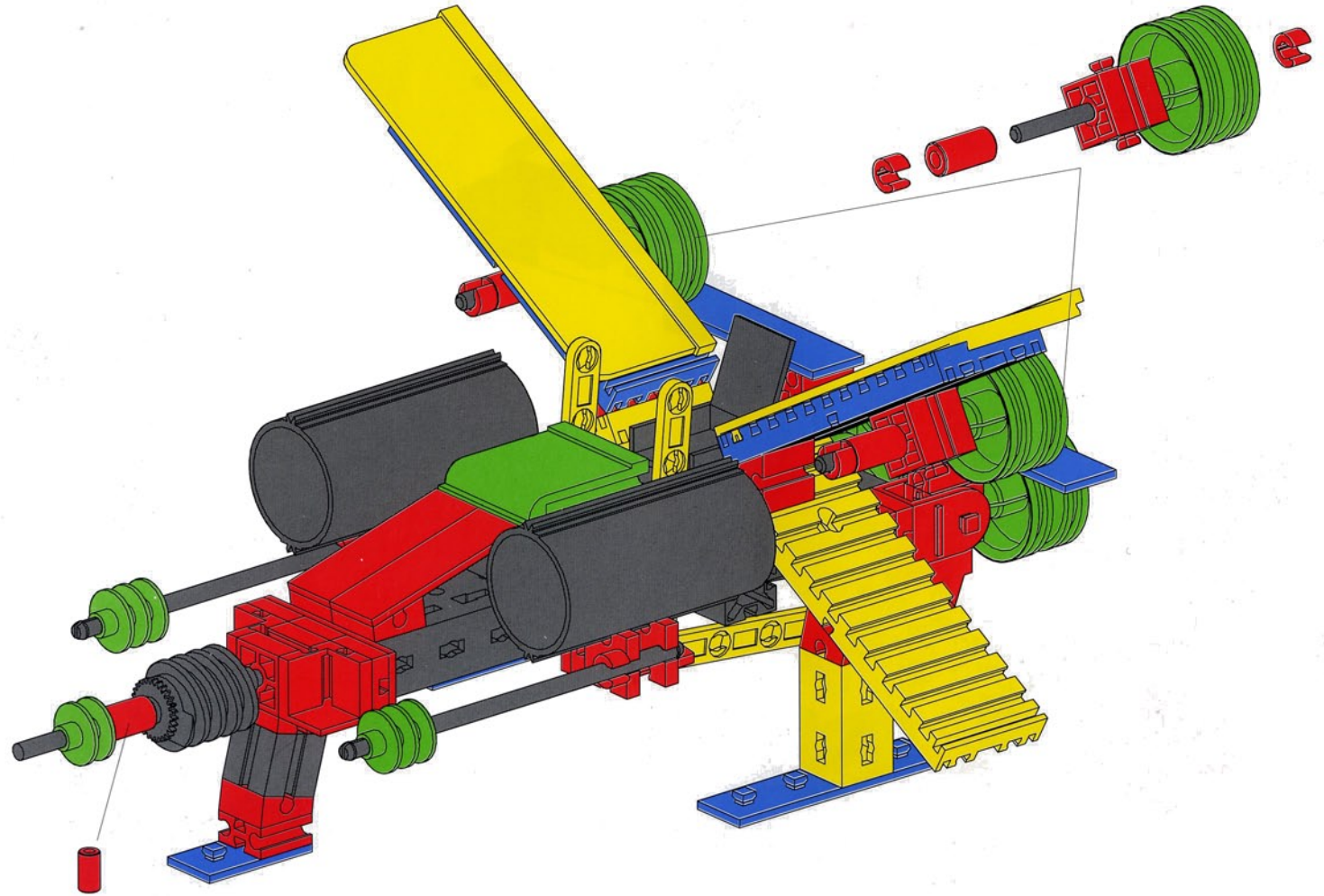
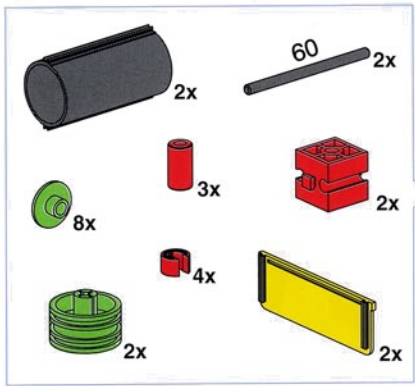

Air Commander

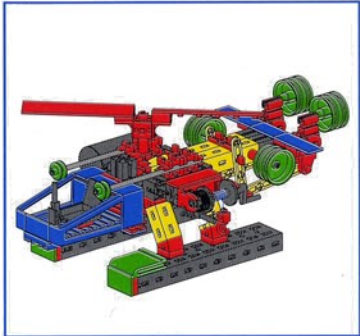

1

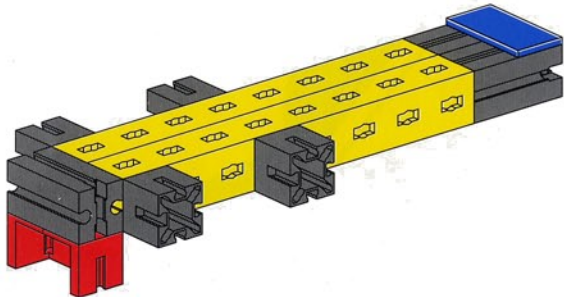
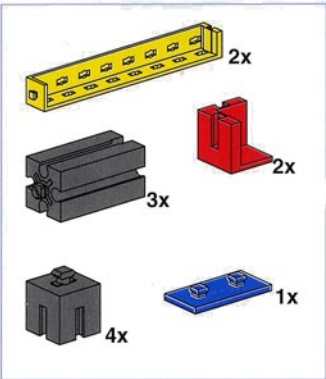

2

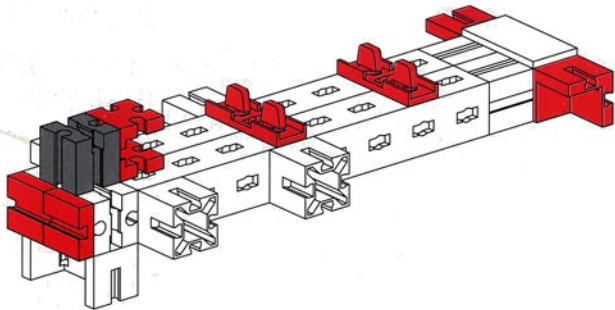
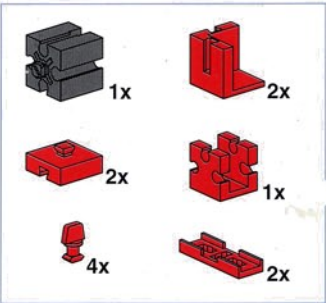

3

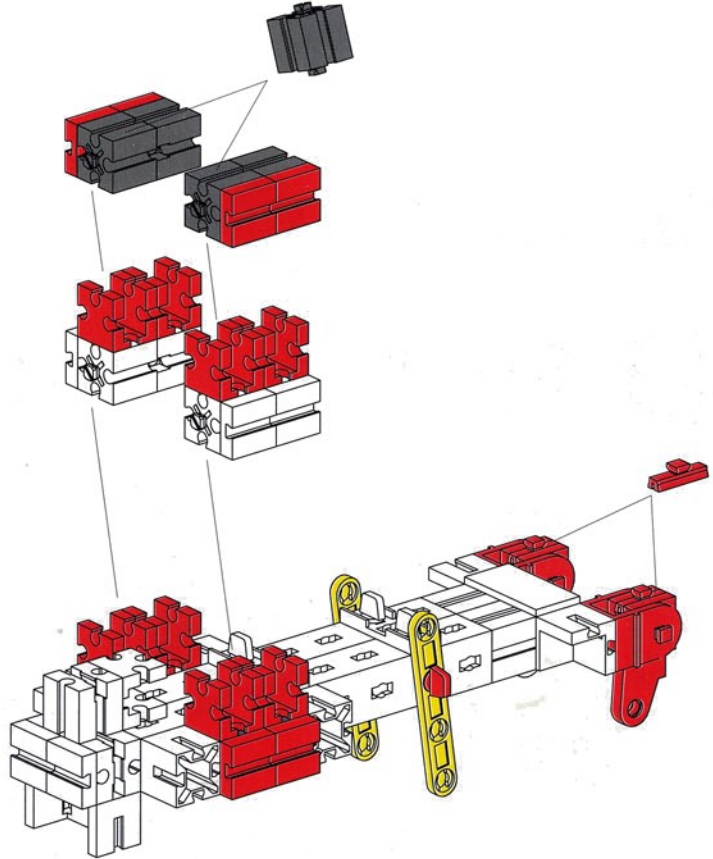
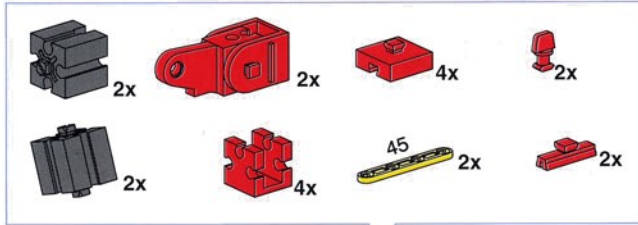

4

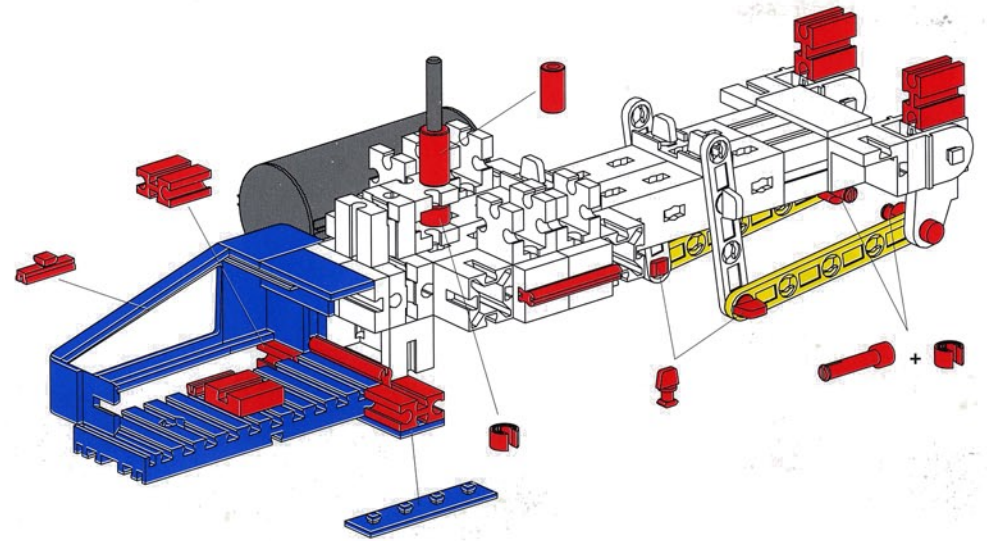
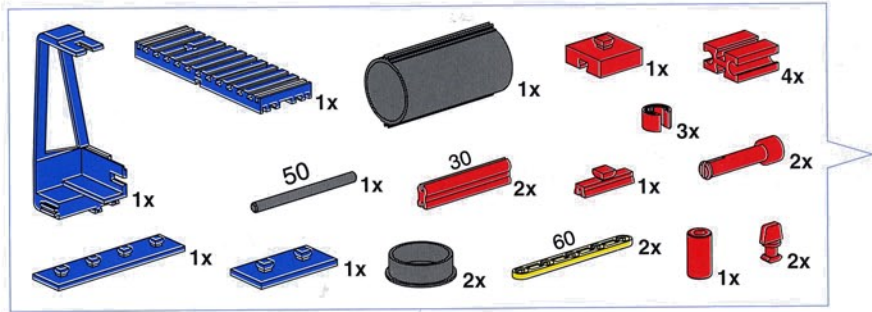

5

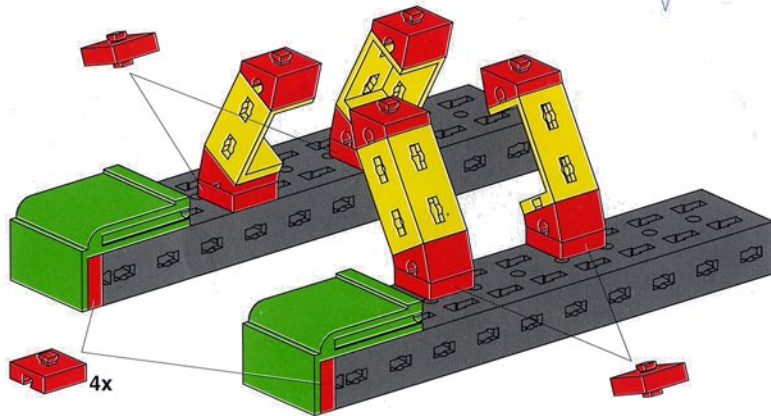
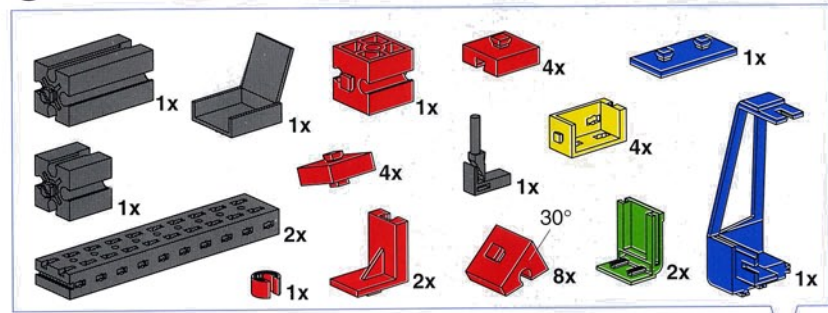

50

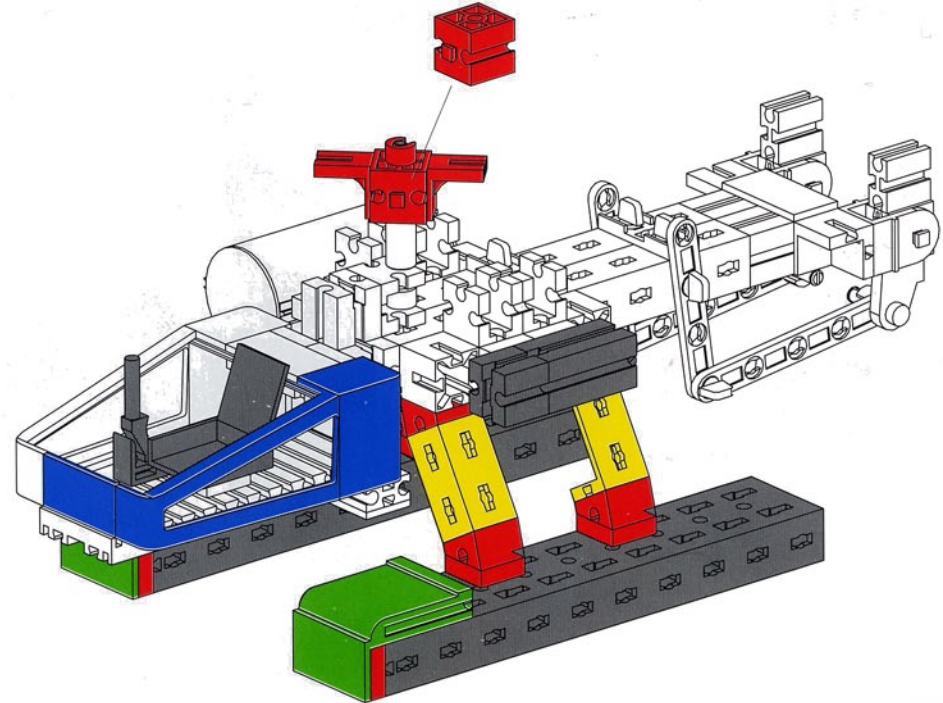

6

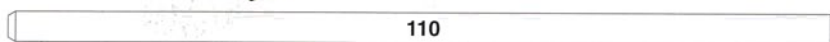
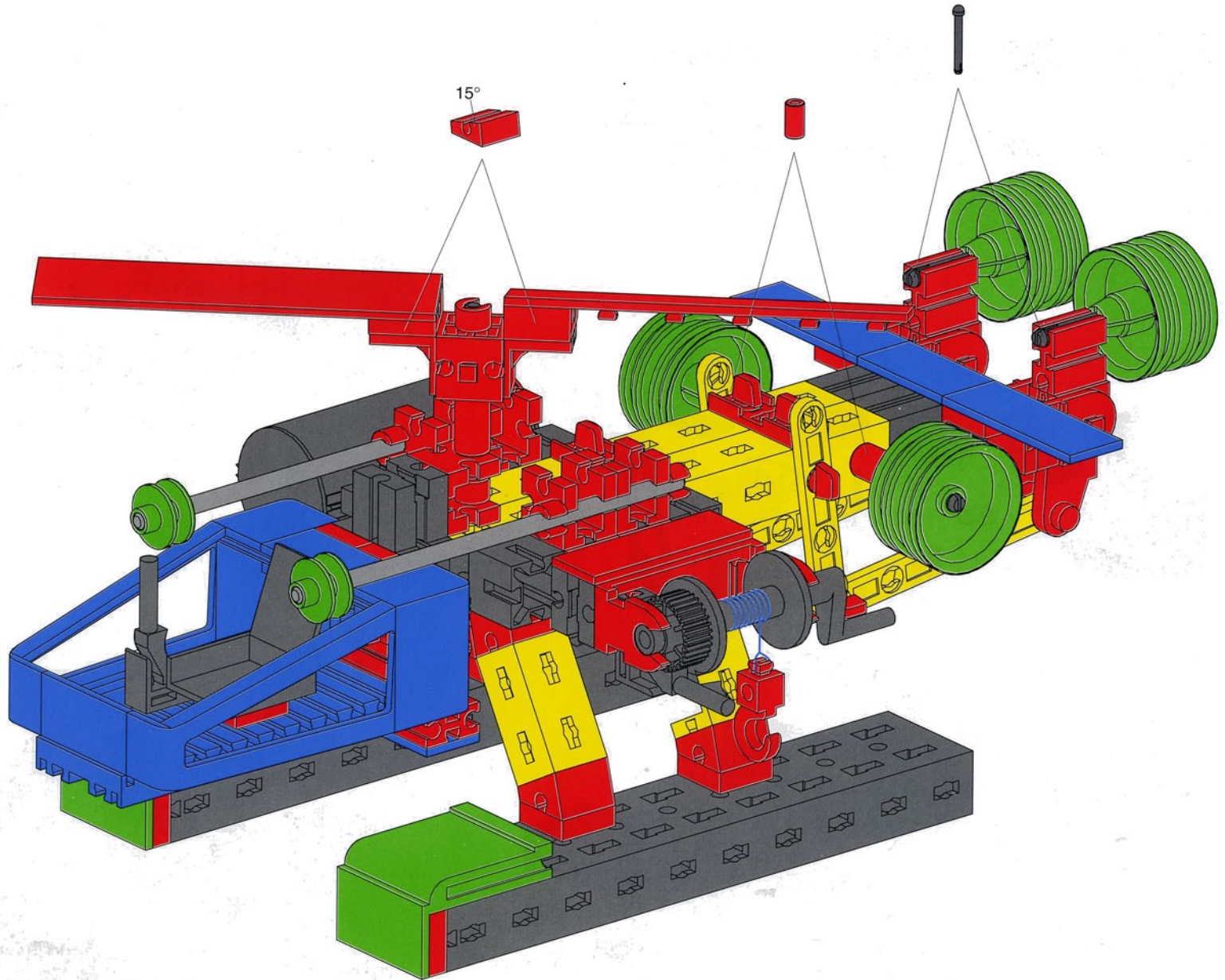
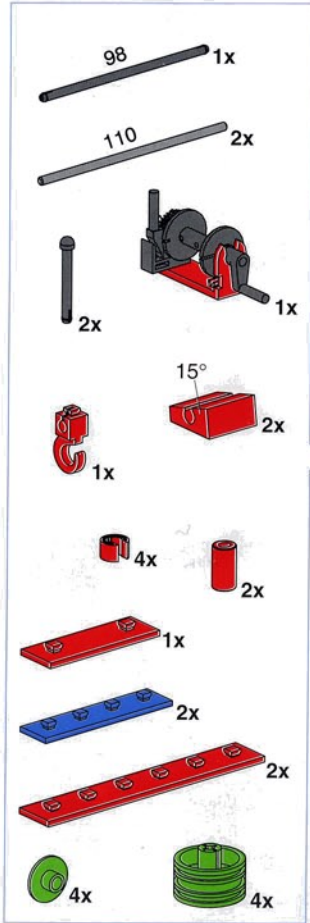

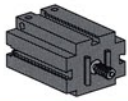

1

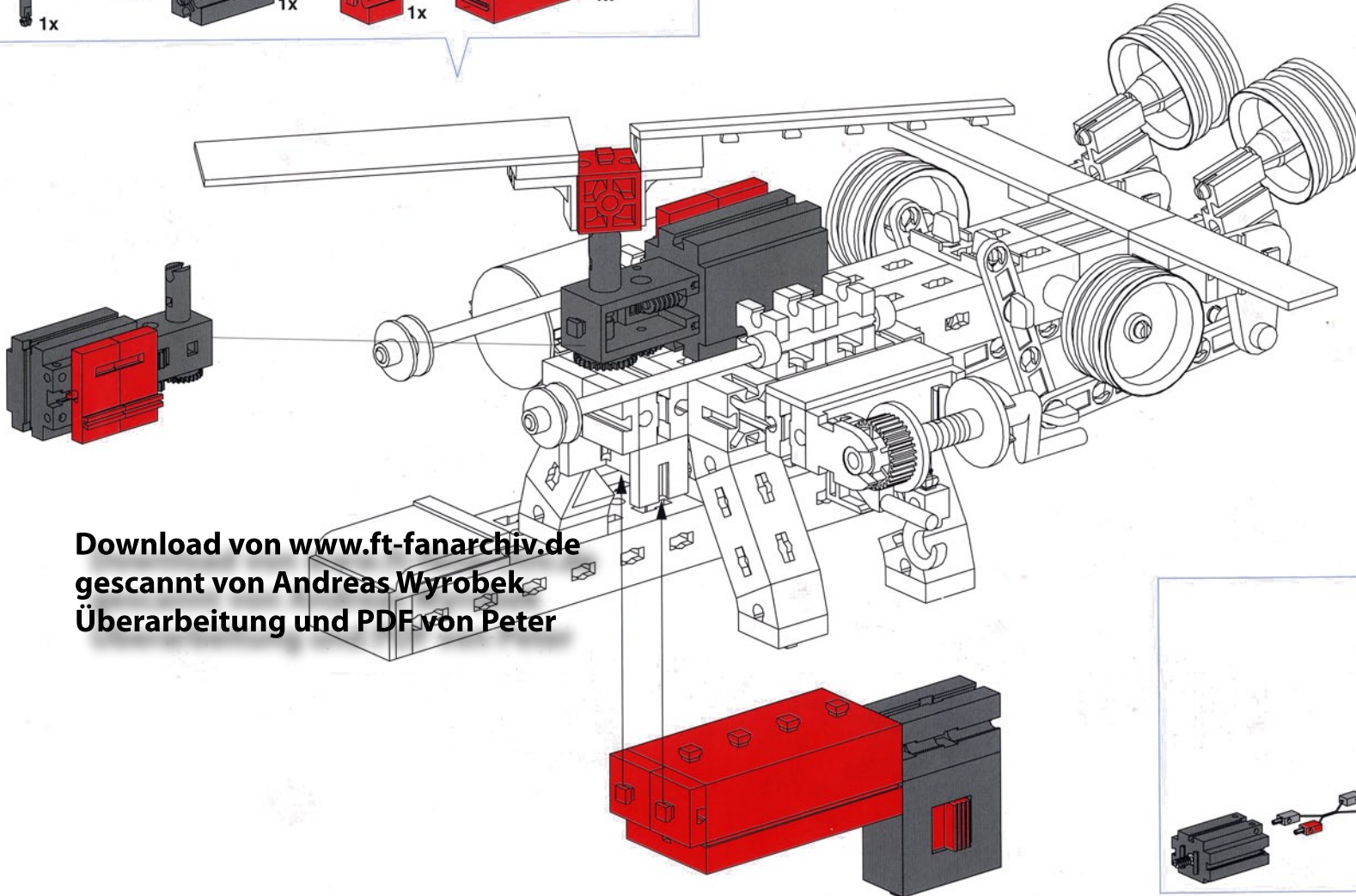
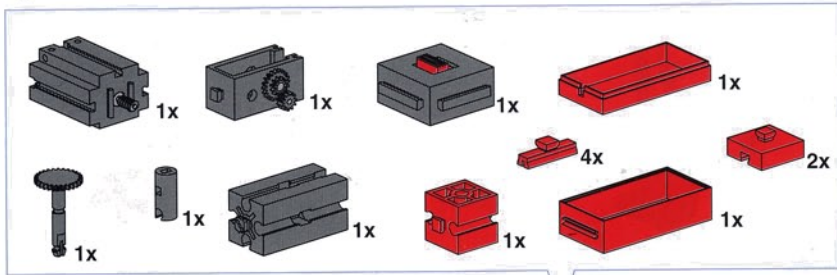

Download von www.ft-fanarchiv.de
gescannt von Andreas Wyröbek
Überarbeitung und PDF von Peter

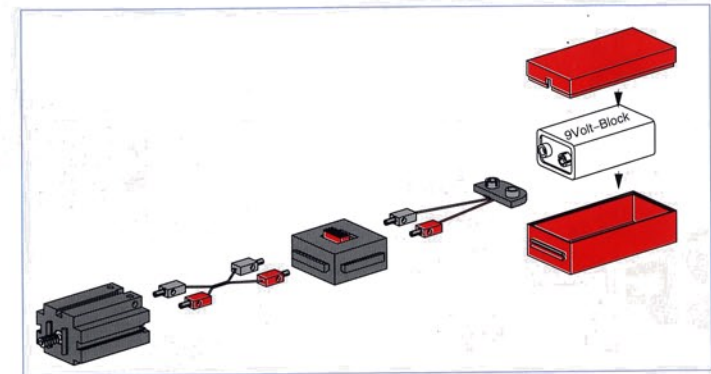

Shuttle Base

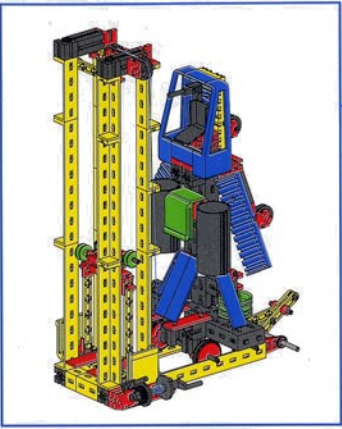

1

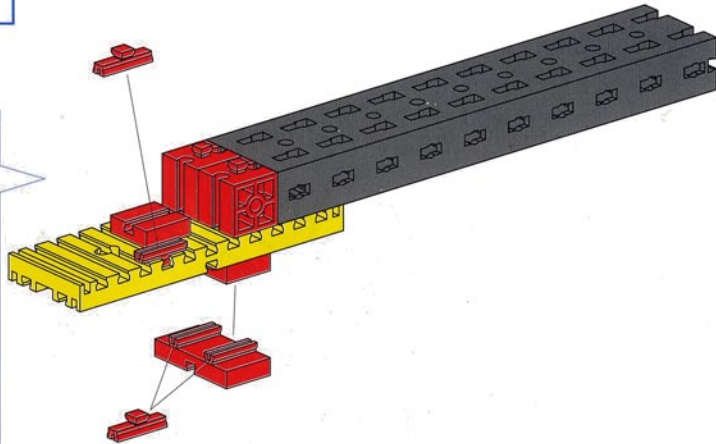
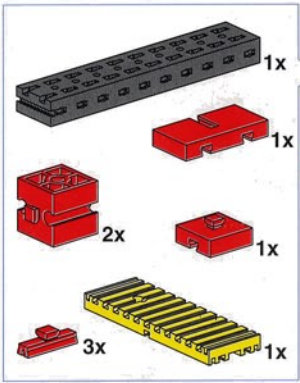

2

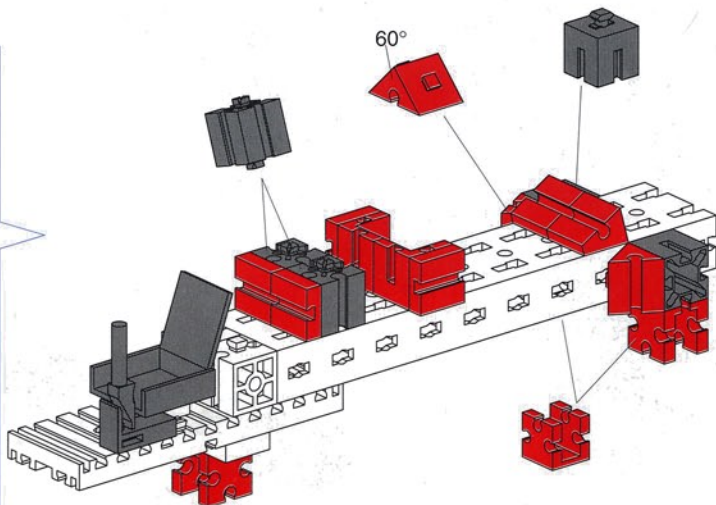
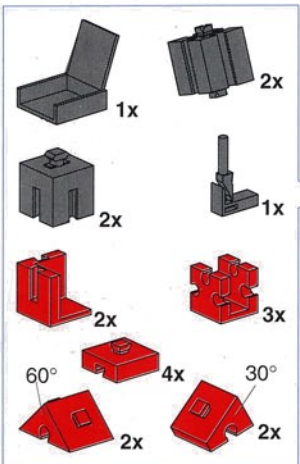

3

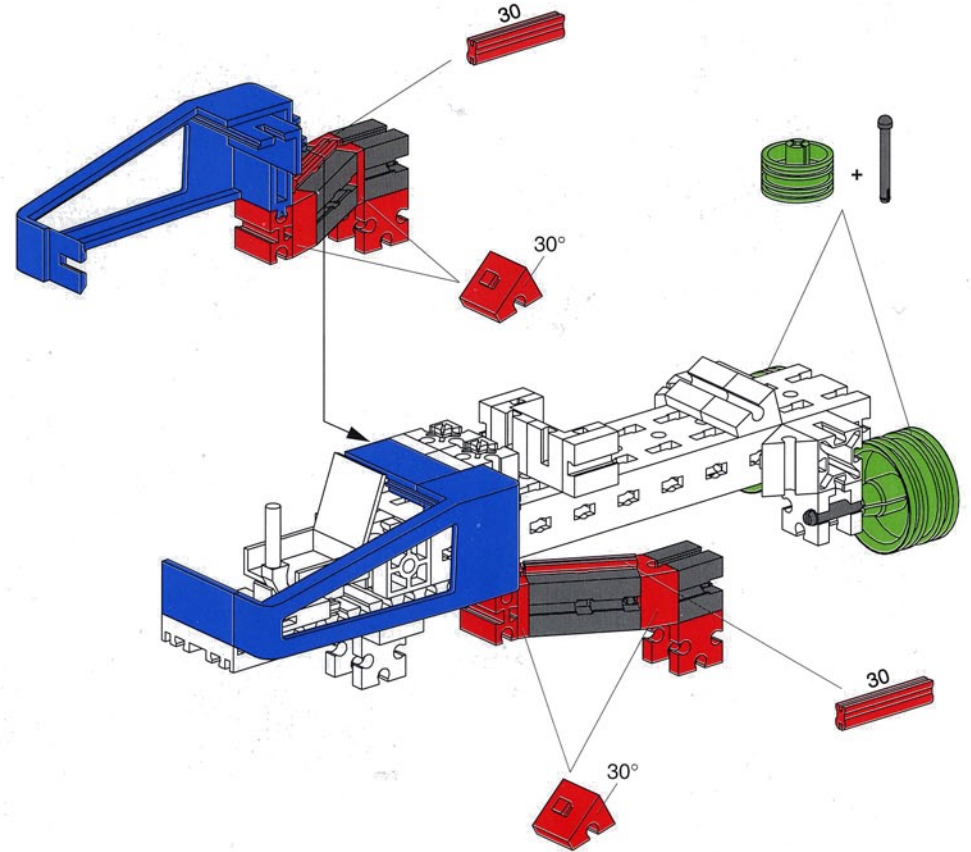
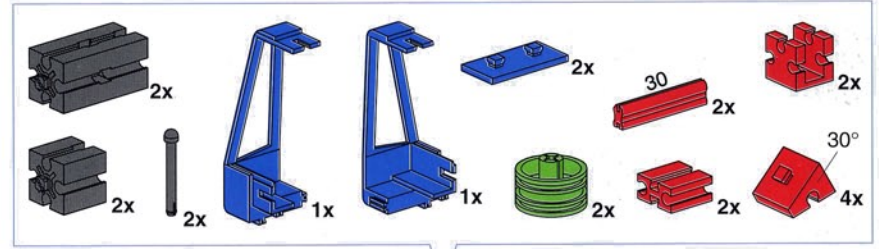

4

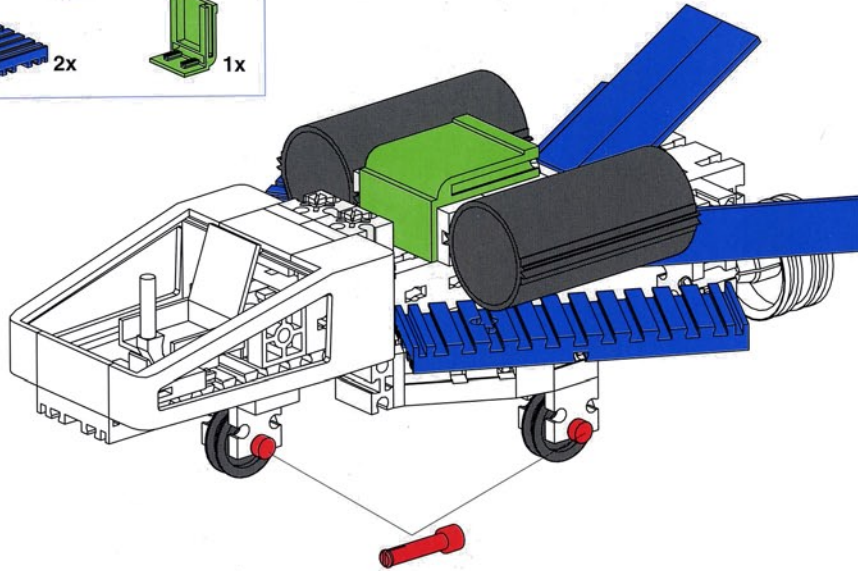
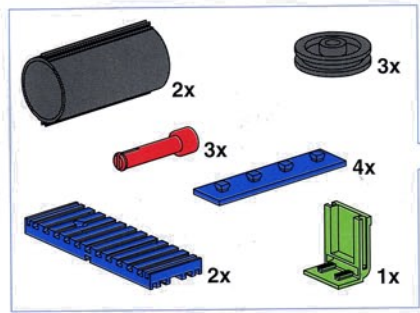

6

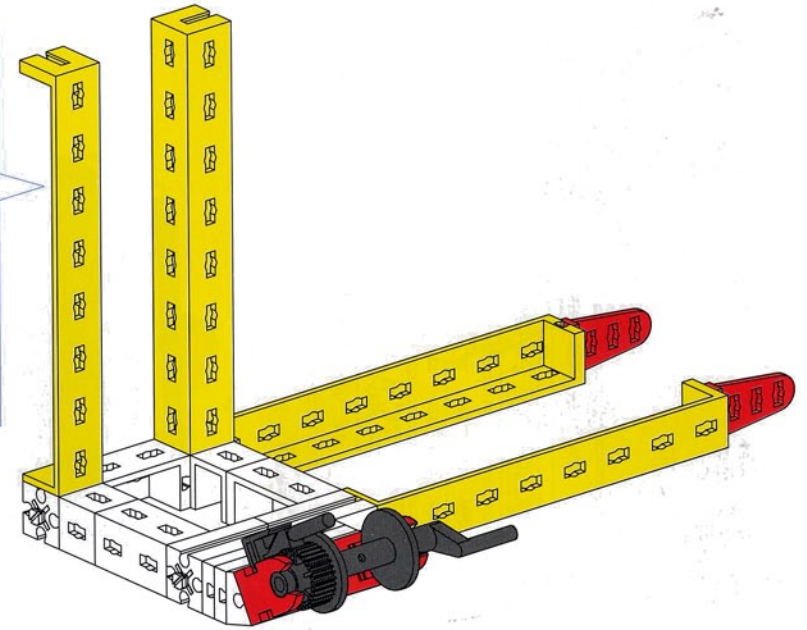
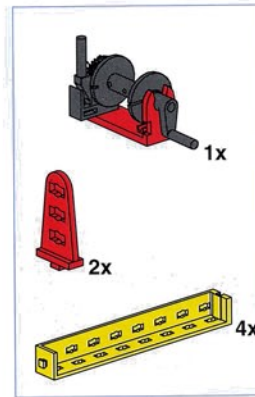

5

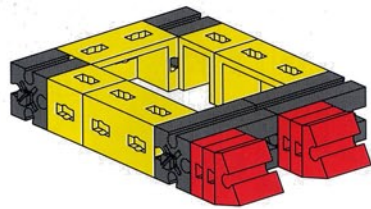
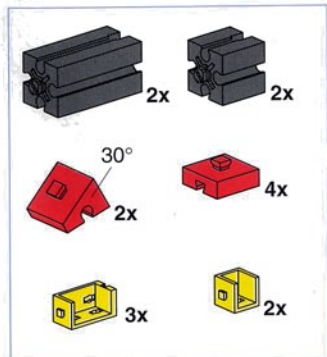

60

7

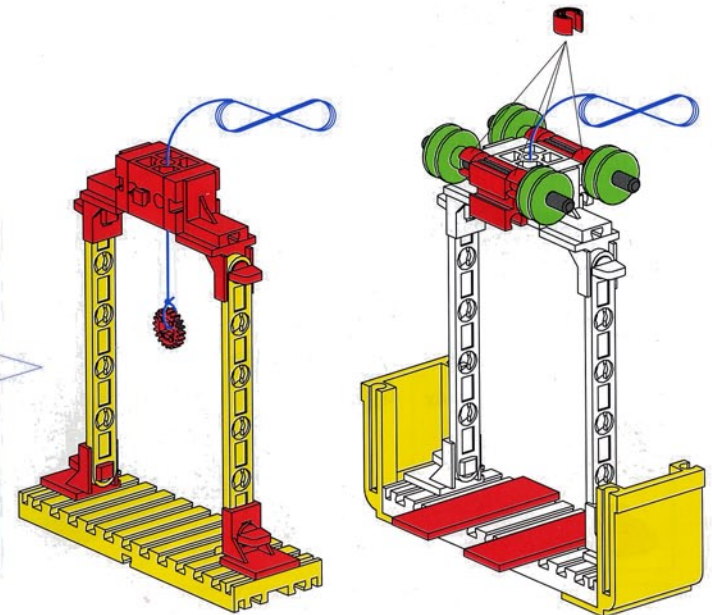
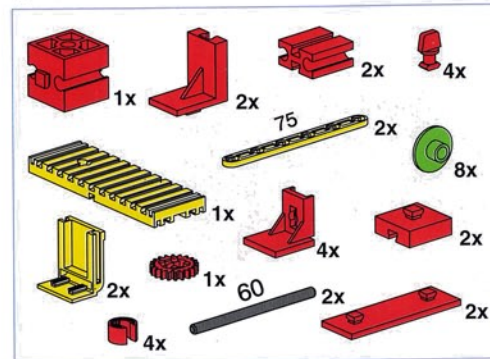

8

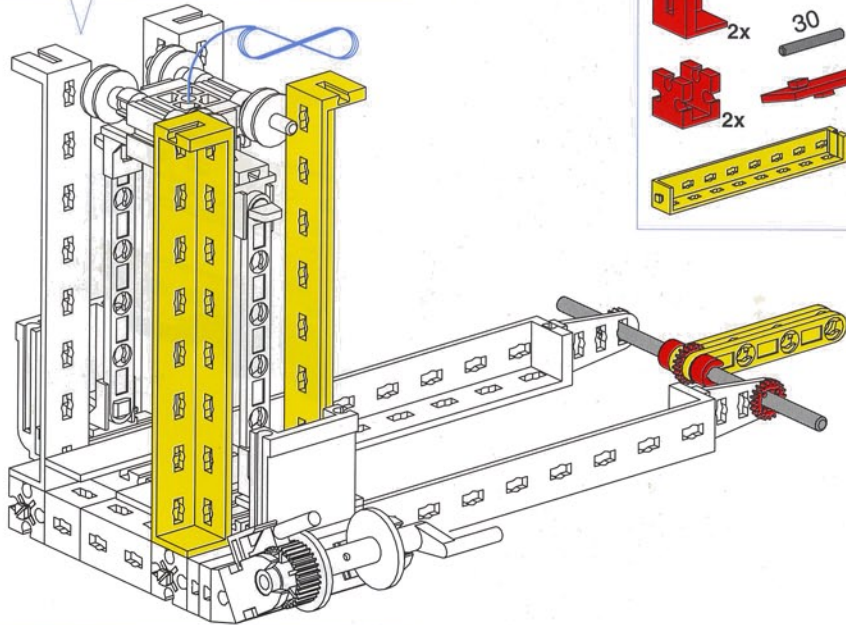
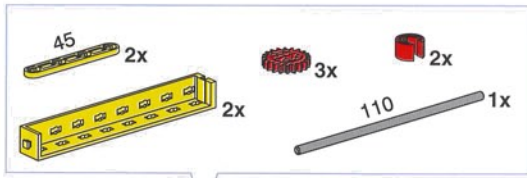

10

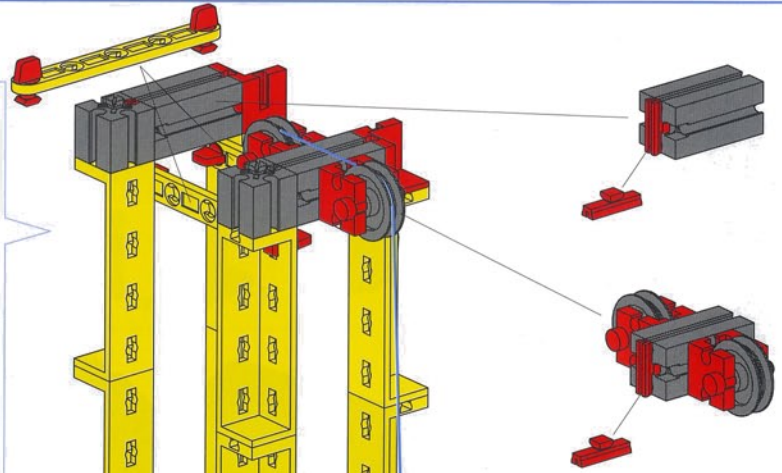
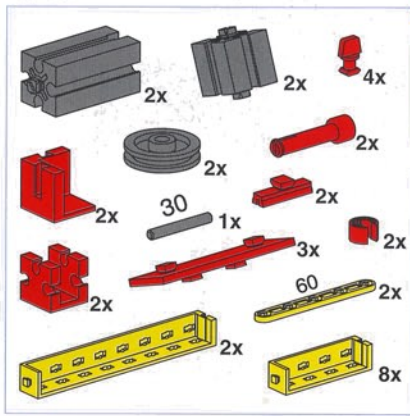

9

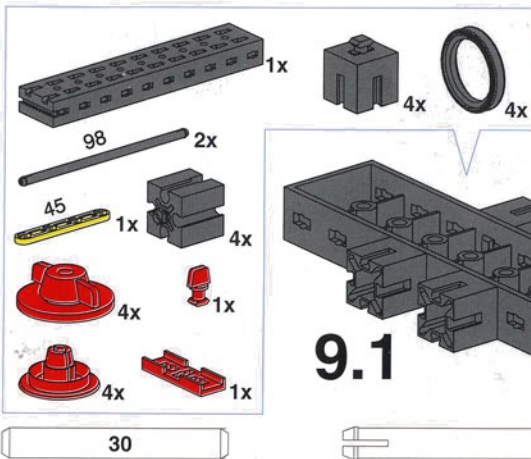

9.1

9.2

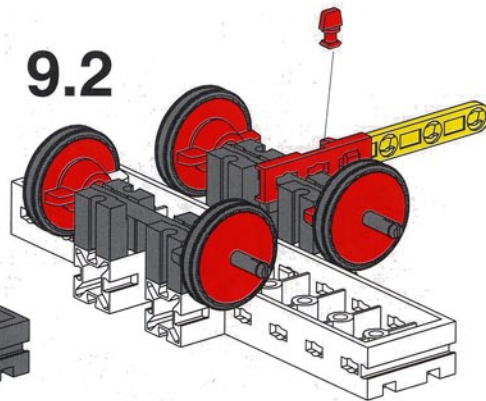

110

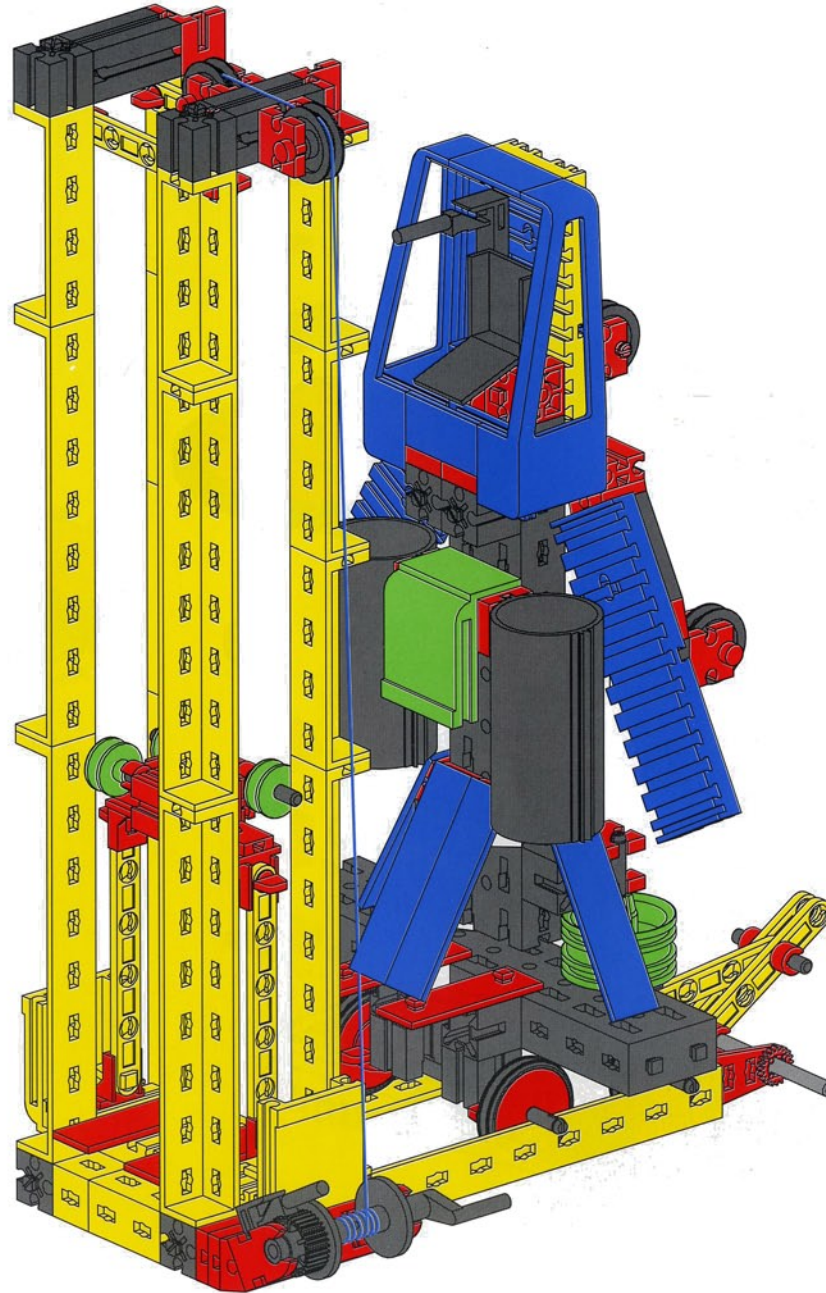

Radar Control



1

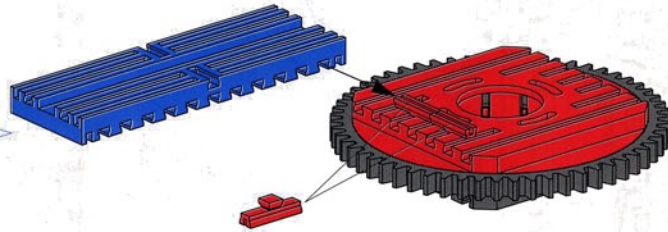
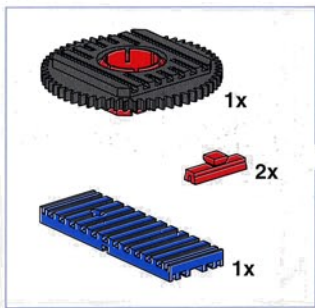

2

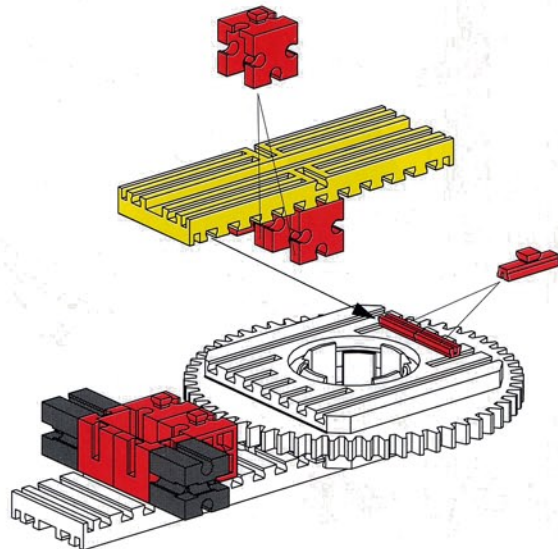
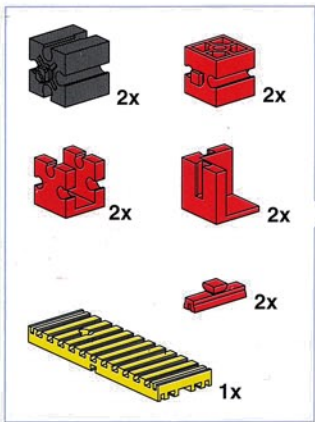

3

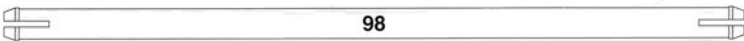
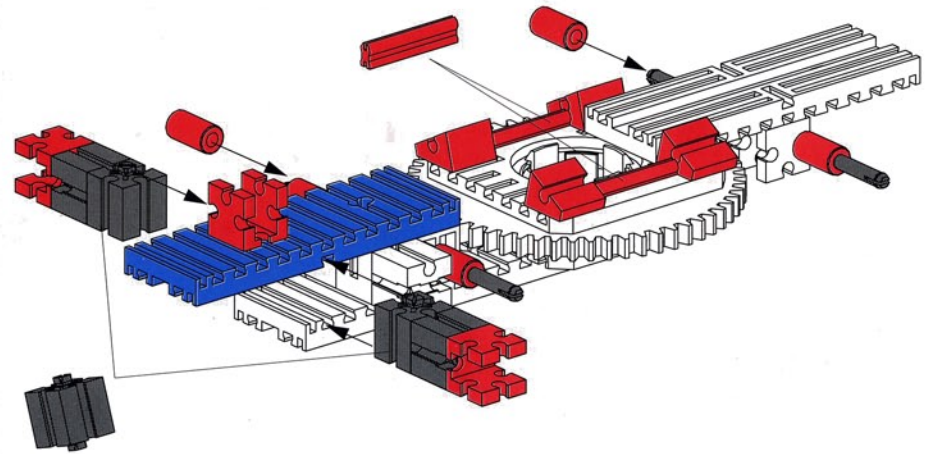
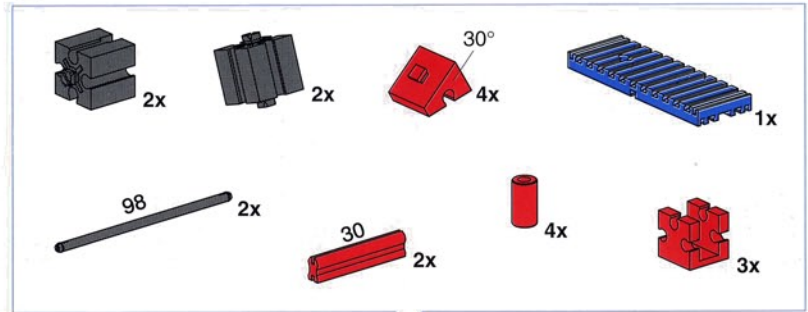

4

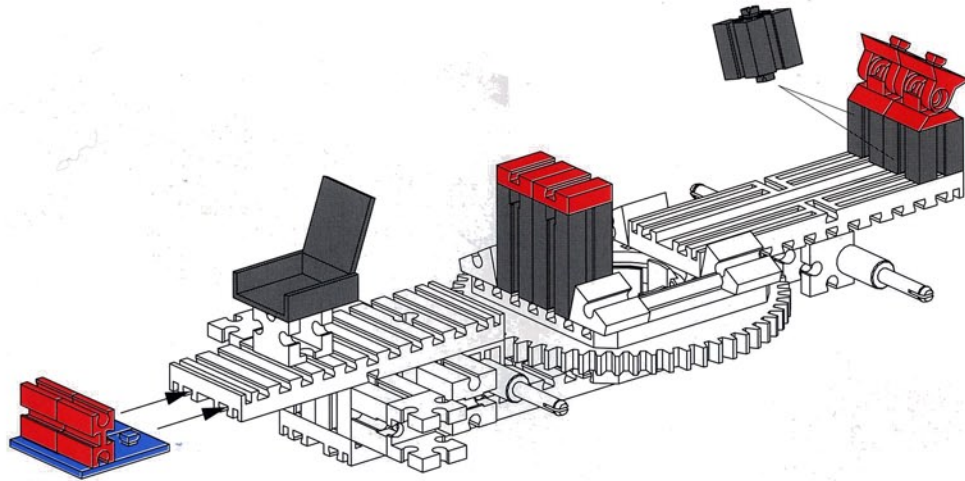
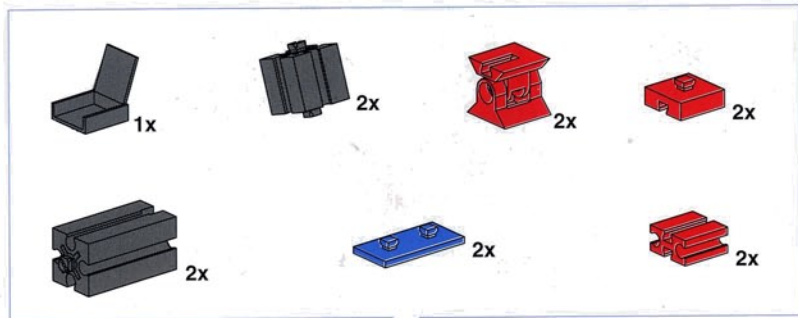

5

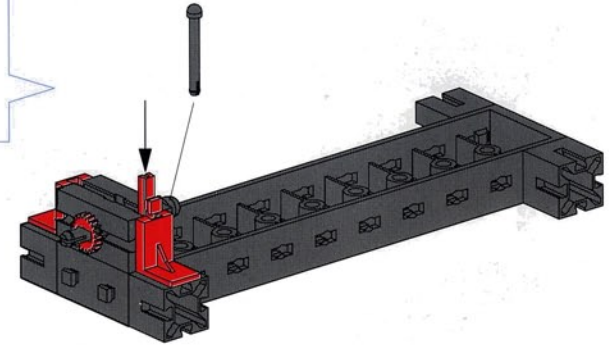
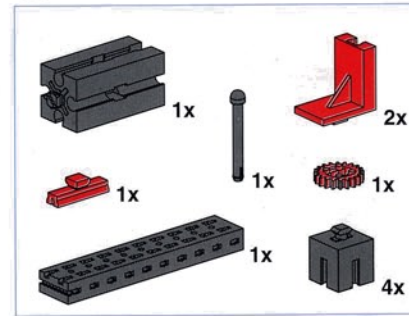

6

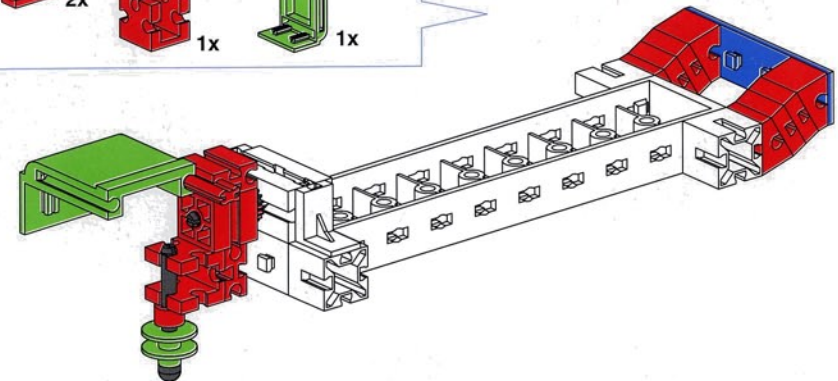
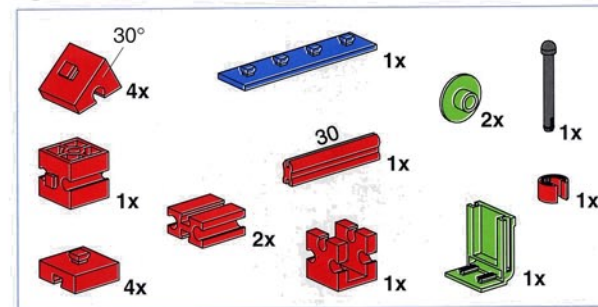

7

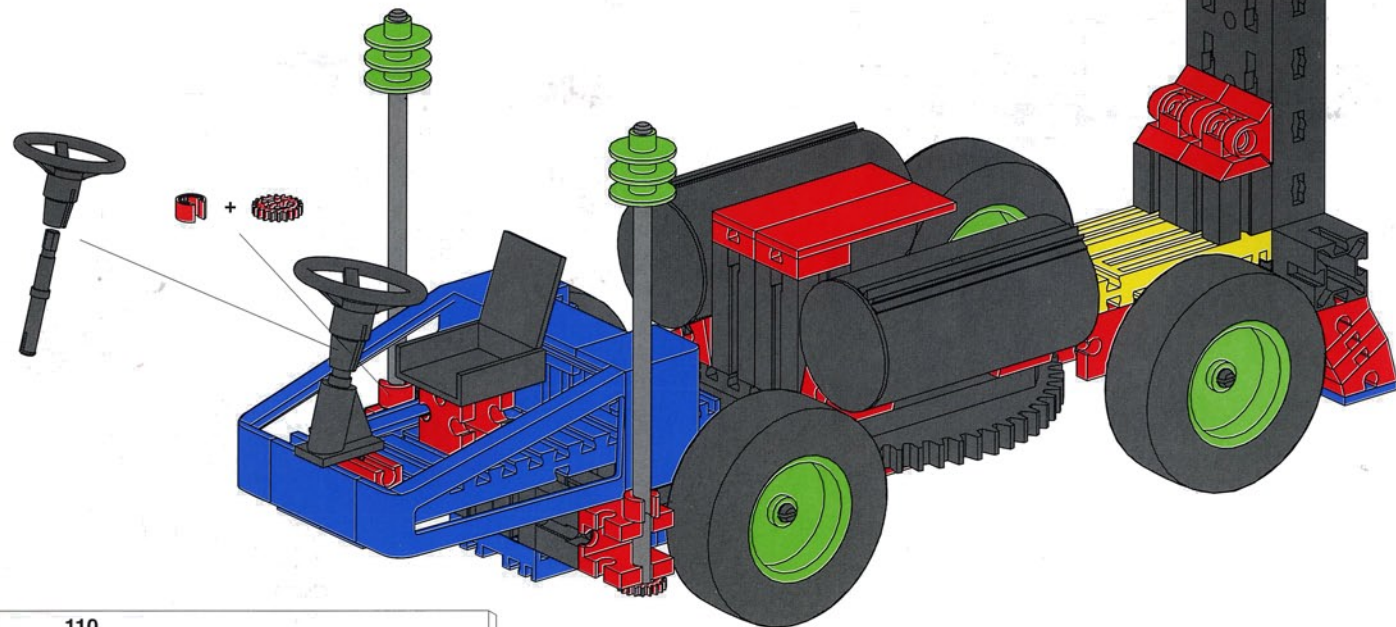
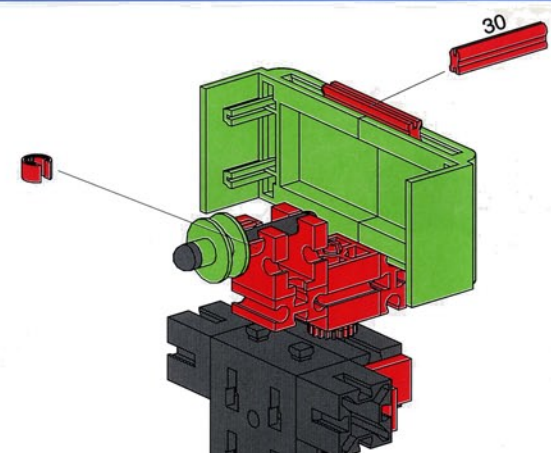
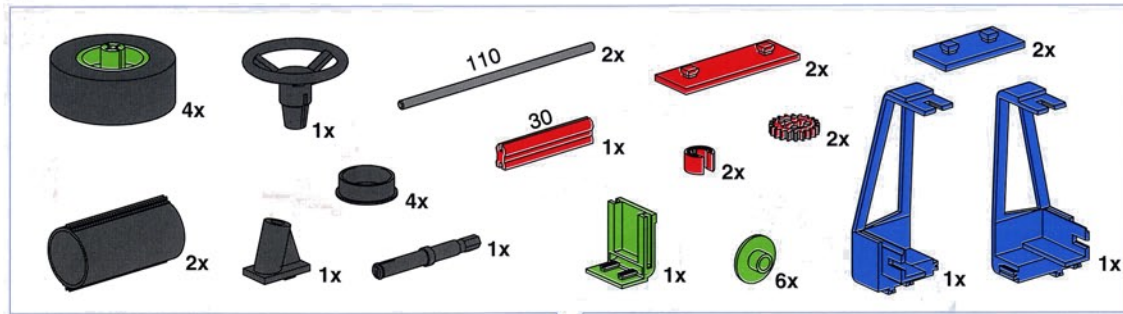

110

Polaris Trailer

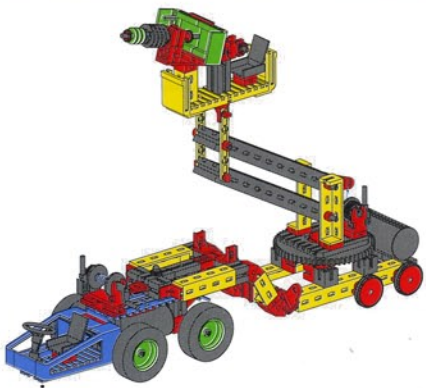

1

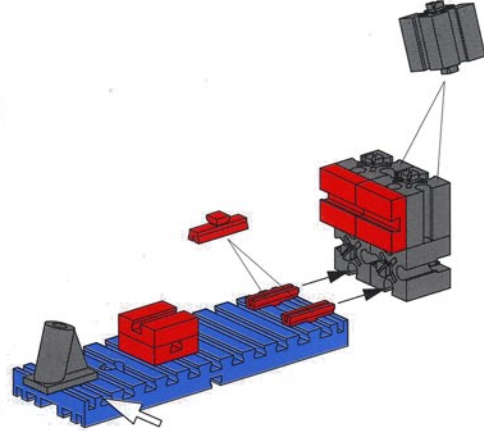
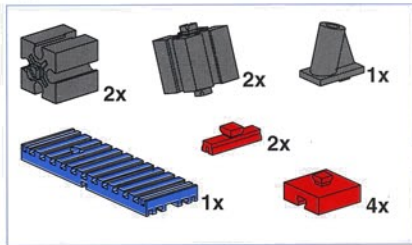

2

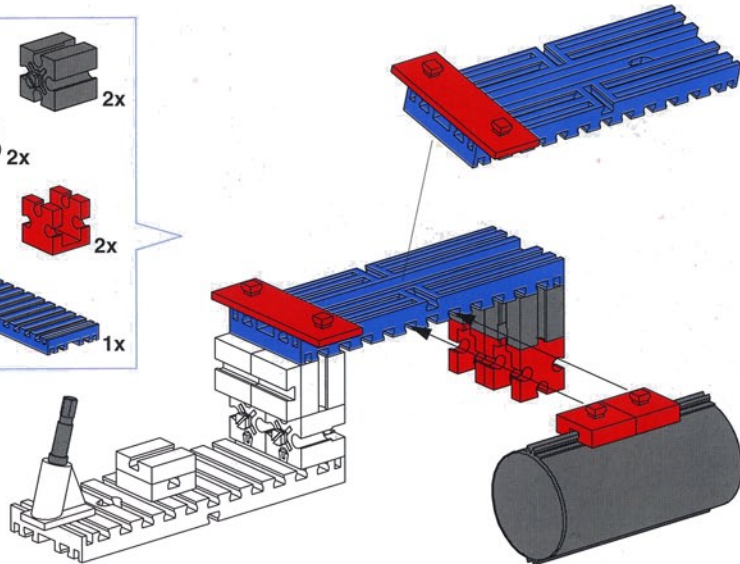
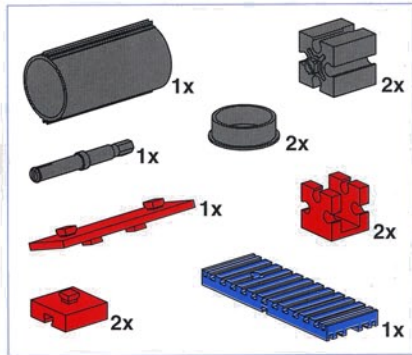

3

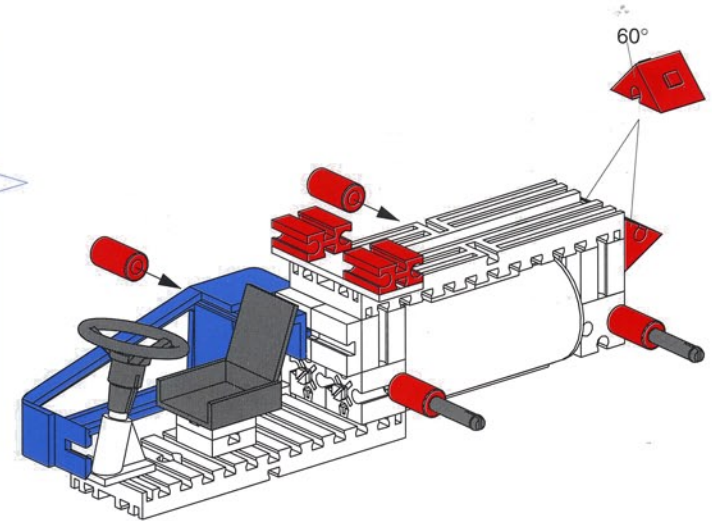
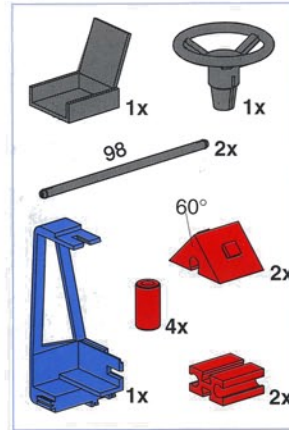

4

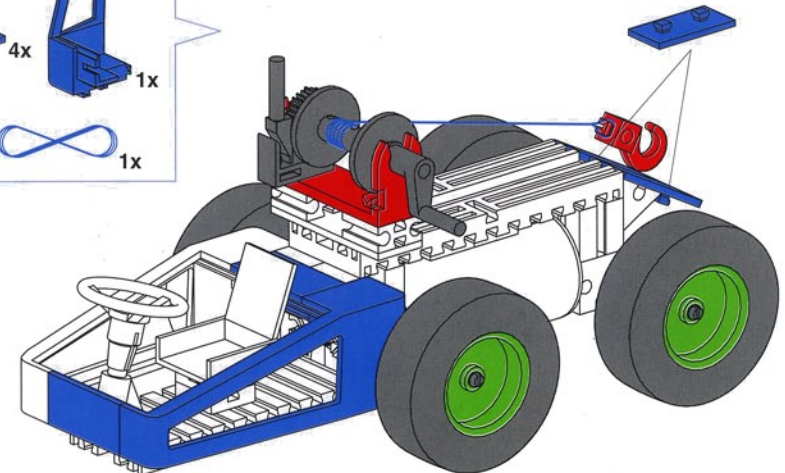
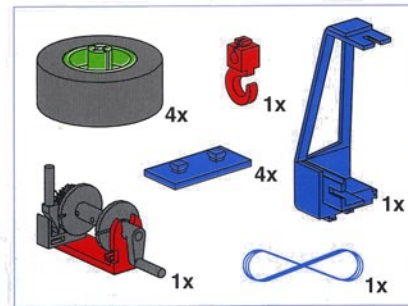

5

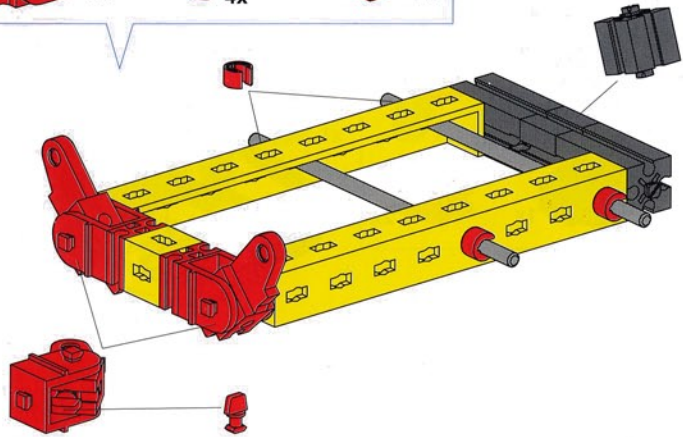
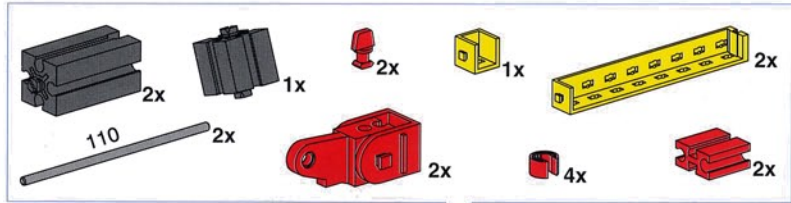

7

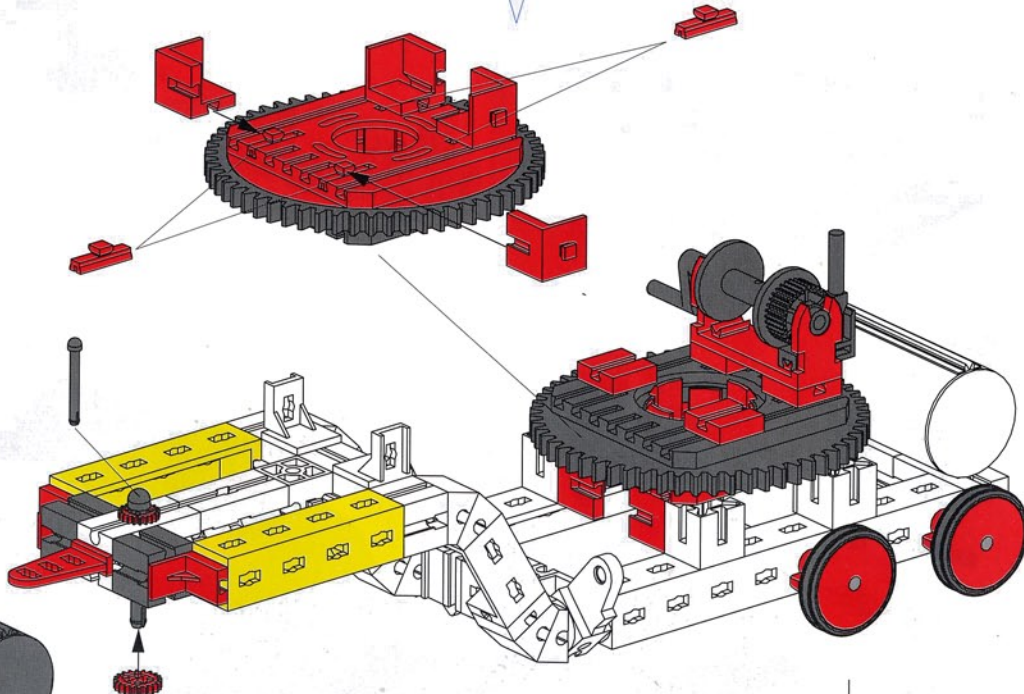
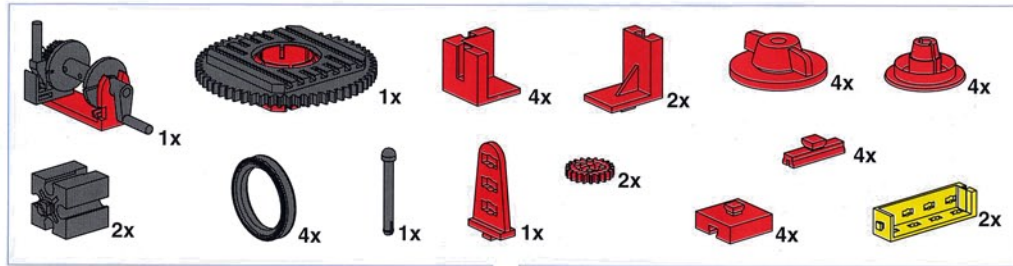

6

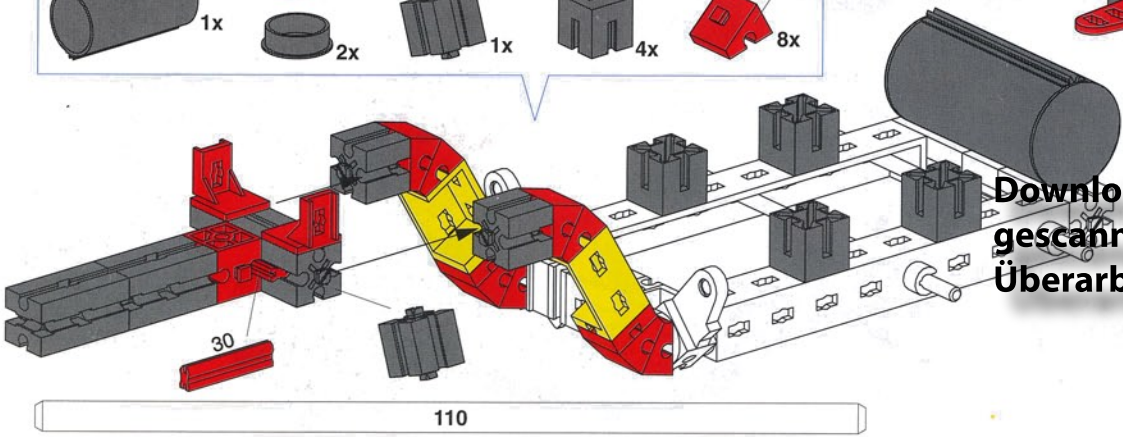
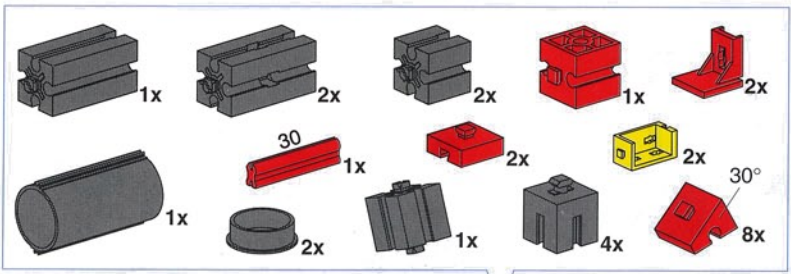

Download von www.ft-fanarchiv.de
 gesamt von Andreas Wyrobek
 Überarbeitung und PDF von Peter



8

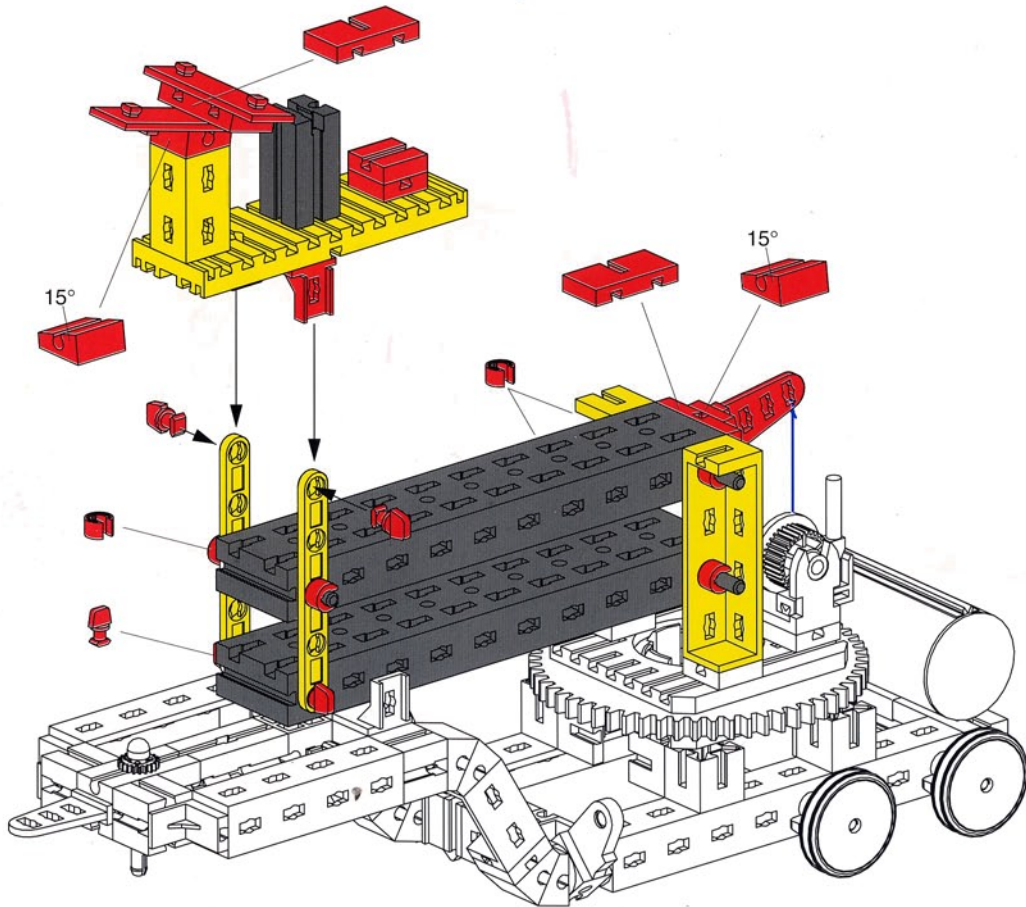
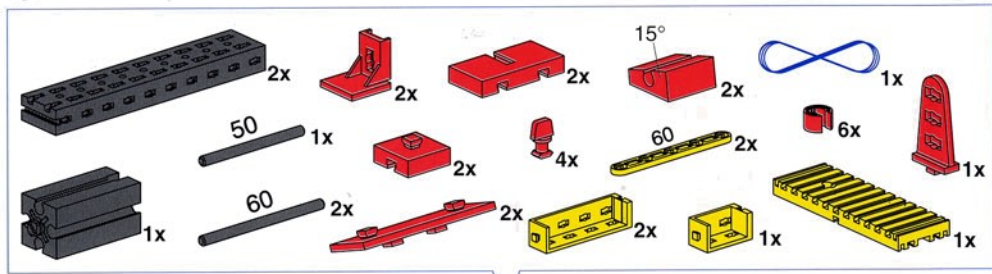

9

